

# FC6-越野卡车

(安装说明书)

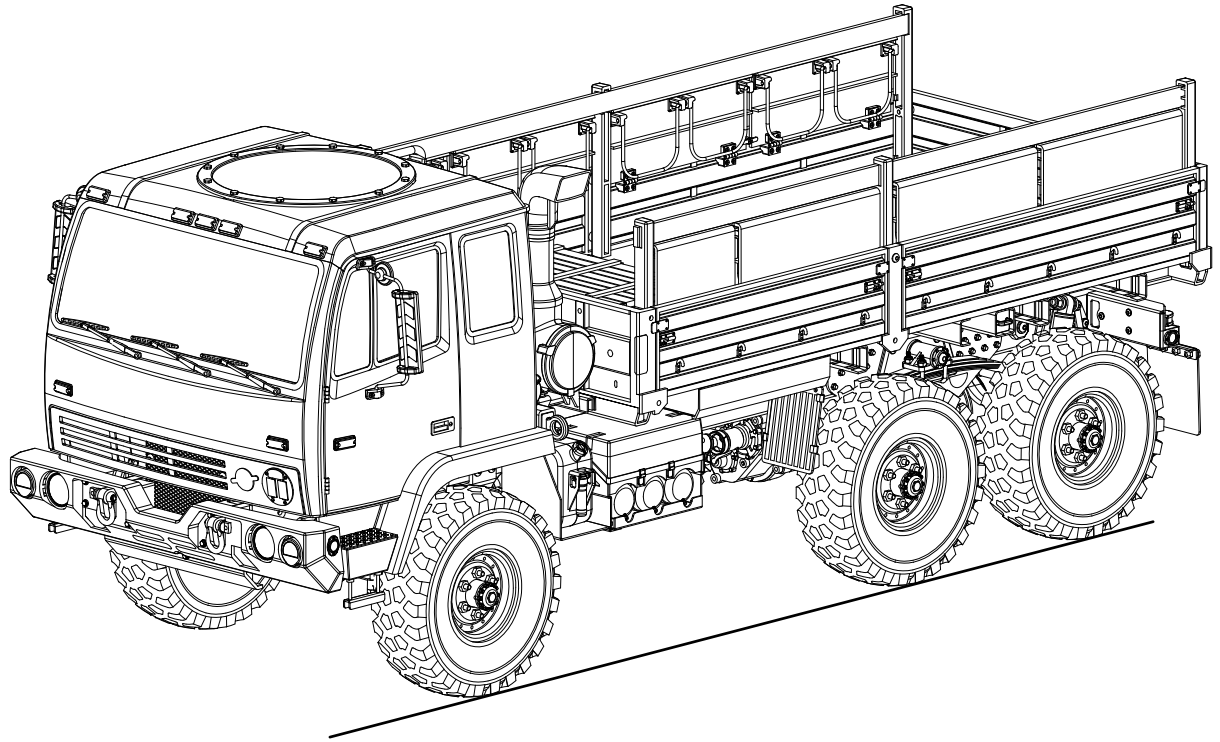

封面另行设计

**CAUTIONS**



To prevent serious personal injury and/or property damage, operate all remotely controlled models in a responsible manner as outlined herein.

◆ **Safety Precautions**

- 1.1 Choose a right place to operate your RC model.
- 1.2 Do not operate your RC model on the street or highway. It can cause a serious damage or a serious accident.
- 1.3 Never operate your RC model near people or animals.
- 1.4 Do not operate RC model in public places like hospital and residential areas.
- 1.5 Never operate RC model indoors. There is a higher possibility of fire or damage.
- 1.6 Keep the parts out of reach of children, small parts can cause choking and vinyl bags can suffocate.
- 1.7 Do not use with children younger than 14 years.

◆ **Inspect your RC model before operation**

- 2.1 Make sure that all screws and nuts are properly tightened. It is also a good idea to use removable thread lock wherever metal screws go into metal, especially for engine mounts and the engine pilot shaft.
- 2.2 Always use fresh batteries for your transmitter and for your receiver to avoid losing control of the model.
- 2.3 Always test the brakes and throttle before starting your engine to avoid losing control of the model.
- 2.4 Always turn on the transmitter first, and then turn on the receiver.

◆ **After operation of your RC model**

- 3.1 Turn off receiver first, then turn off transmitter, this will prevent runaways.
- 3.2 Be careful when handling batteries, they will be hot after running.
- 3.3 Replace any batteries that have been dented or have frayed wires, short circuits can cause fire.

**TOOLS**  
(Not included)

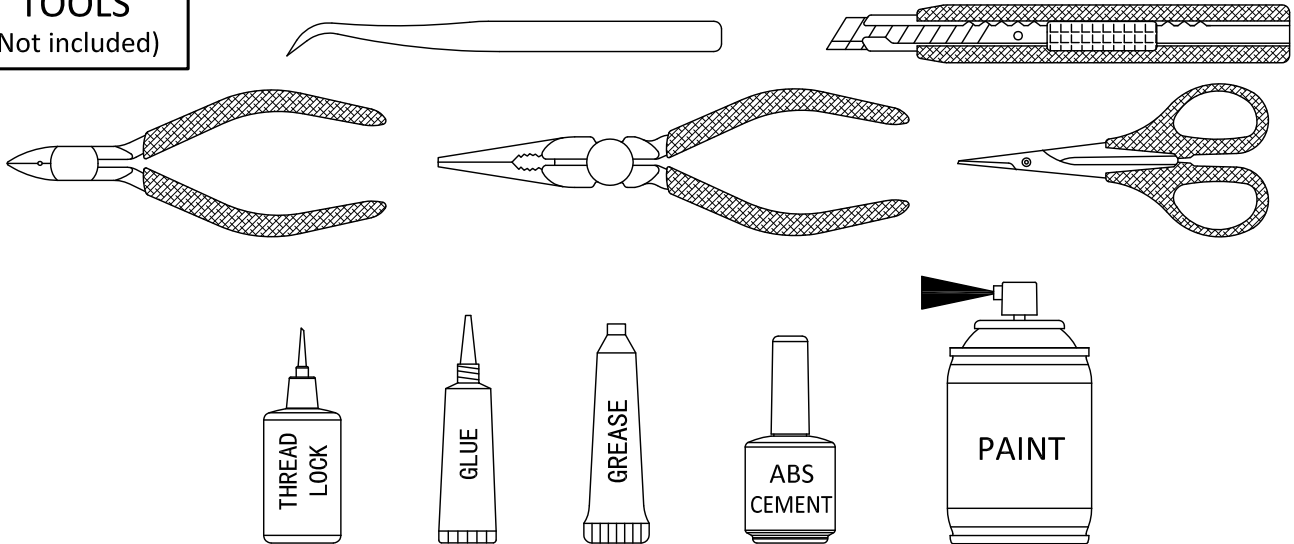

**Electronic equipment**  
(Not included)

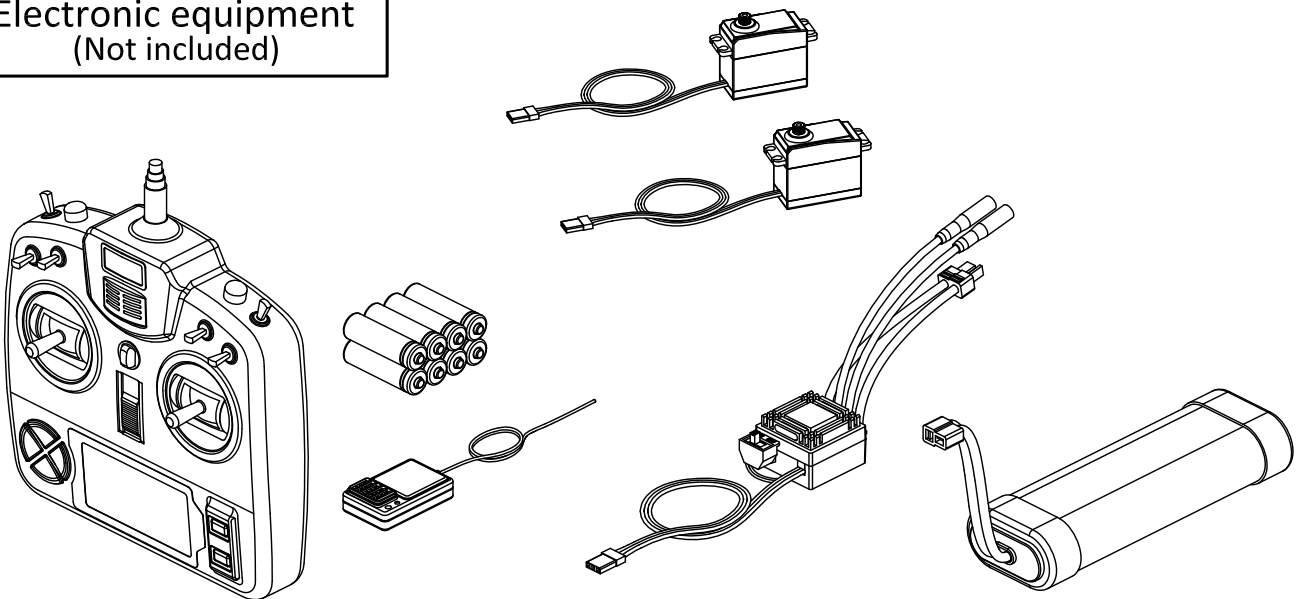

**PLANK**

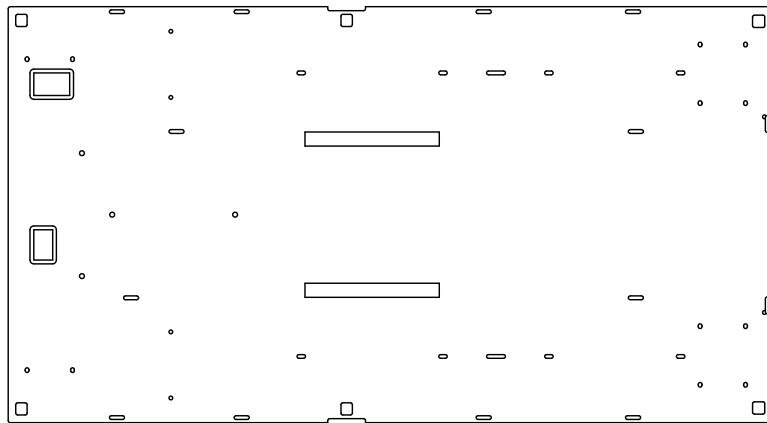

64701 X1

64704 X2

64705 X2

64706 X2

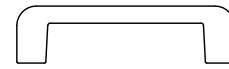

64709 X1

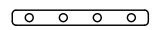

62032 X2

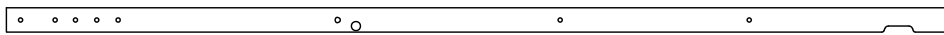

64702 X2

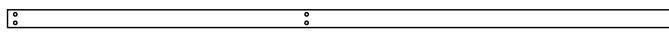

64703 X2

**FRAMES**

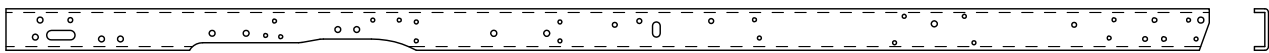

43313 X1

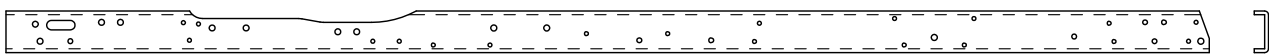

43314 X1

**DAMPER**

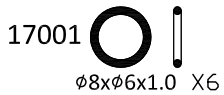

17001  
ø8xø6x1.0 X6

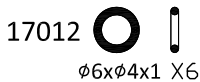

17012  
ø6xø4x1 X6



210501 X6



41401 X6



41402 X6



17011  
ø5xø2x1.5 X12



41336 X12



210502 X6

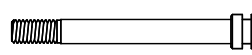

41403 X6



41307 X6

**WHEELS**



12204  
M4 X6

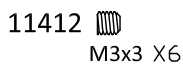

11412  
M3x3 X6

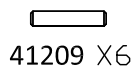

41209 X6

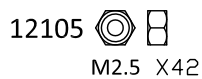

12105  
M2.5 X42



32202 X7

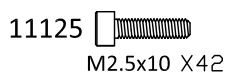

11125  
M2.5x10 X42



34405 X6

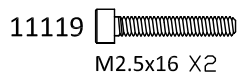

11119  
M2.5x16 X2

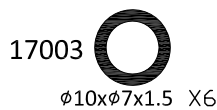

17003  
ø10xø7x1.5 X6

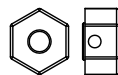

44091 X6

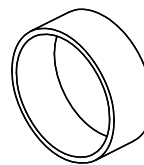

41348 X7

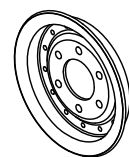

71071 X7

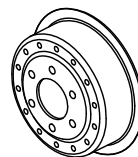

71072 X7

**TIRES**

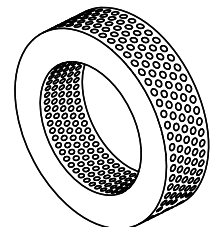

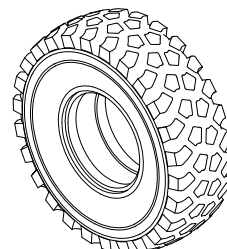

42303 X7



50009 X7

**TRANSMISSION GEAR BOX**

11401  M3x4 X1

13003   $\phi 2.5 \times \phi 6 \times 0.4$  X2

41446   $\phi 5.1 \times \phi 8 \times 1.5$  X2

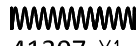

11102  M2x6 X2

14102   $\phi 3 \times \phi 7 \times 0.5$  X2

 41307 X1

11106  M3x8 X2

15003   $\phi 5 \times \phi 10 \times 4$  X12

  41373(14T) X1

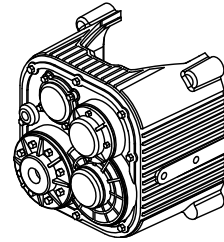

31401 X1

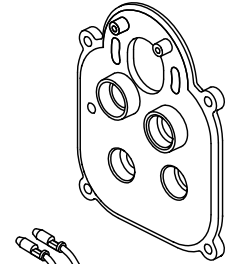

31402 X1

11219  M3x4 X3

72003   $\phi 5 \times \phi 8 \times 0.5$  X1

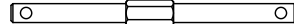
 41263 X1



31403 X1



31405 X1

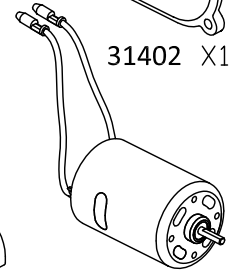

10602 X1 (540-35T)

11207  M3x10 X4

 41129 X1

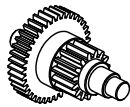

41508 X1

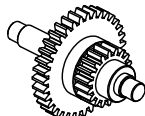

41509 X1

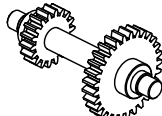

41510 X1



41511 X1

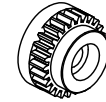

41512 X1

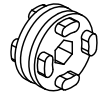

41513 X1

11209  M3x14 X1

11211  M3x18 X1

12203  M3 X2

12303  M3 X1

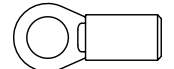
 200103 X2



41104 X1

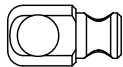

41144 X1



41145 X1

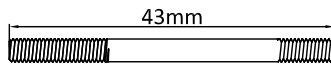

41146 X1



41324 X2



41336 X1

**LIGHTING SYSTEM**

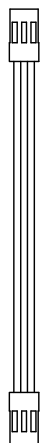

86018 X3

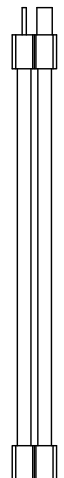

86056 X1

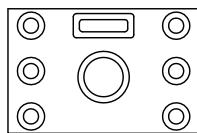

85214 X1

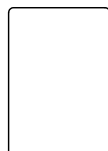

64707 X1

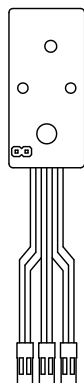

87111 X1

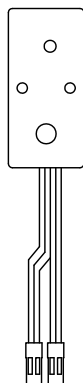

87105 X1



87106 X1



13101 X15



91002 X1



85216 X1

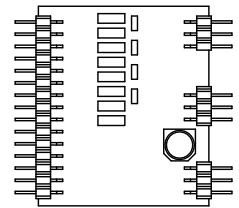

87007 X1

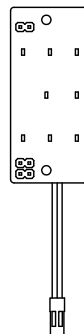

87107 X1



87108 X1

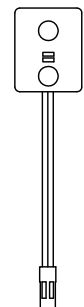

87109 X1



87110 X2

DRIVE SHAFTS



M4x11 X6



95041 X2



95042 X1

AXLES

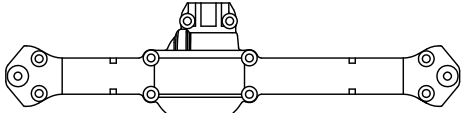

34001 X1

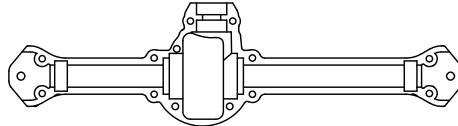

34002 X1

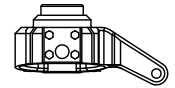

34003 X1

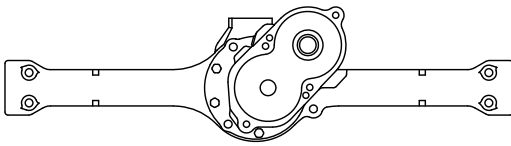

34101 X1

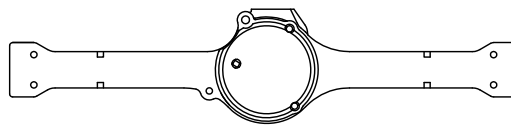

34102 X1

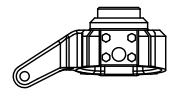

34004 X1

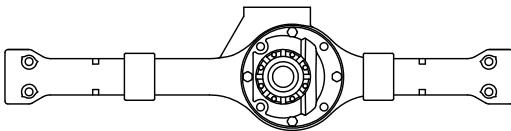

34201 X1

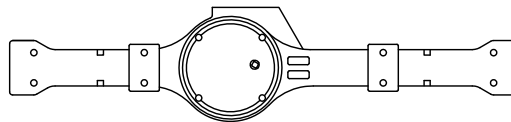

34202 X1

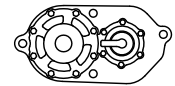

34103 X1



32101 X3

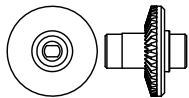

32102 X3



41205 X4

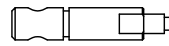

41246 X2

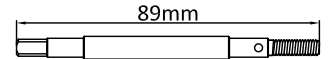

41247 X1

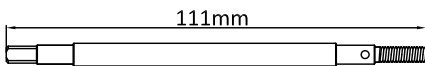

41249 X1



41259 X2

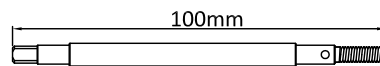

41560 X2

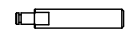

41561 X1

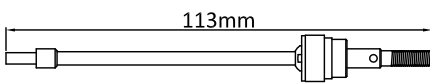

95081 X1

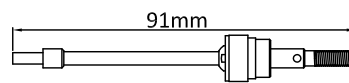

95082 X1

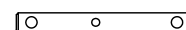

41562 X1



41563 X2

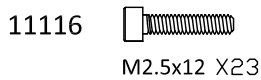

11116

M2.5x12 X23

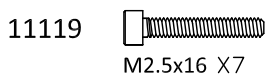

11119

M2.5x16 X7

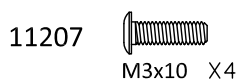

11207

M3x10 X4



11601

M3x16 X2

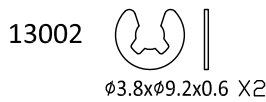

13002

ø3.8xø9.2x0.6 X2

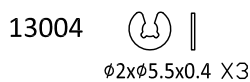

13004

ø2xø5.5x0.4 X3

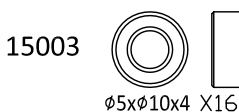

15003

ø5xø10x4 X16

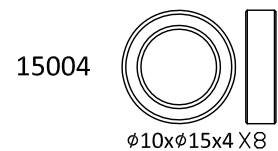

15004

ø10xø15x4 X8

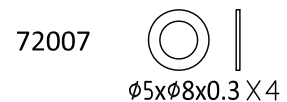

72007

ø5xø8x0.3 X4

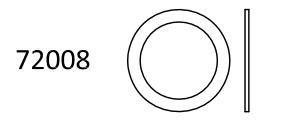

72008

ø10.2xø13.5x0.2 X6

**BATTERY BOX**

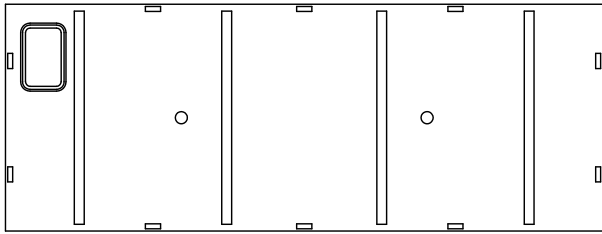

28801 X1

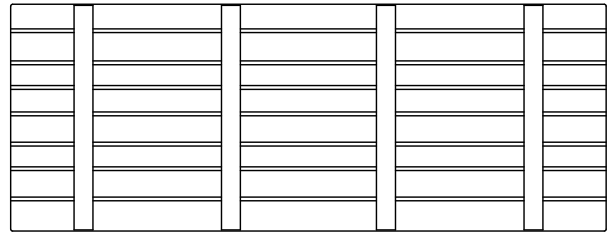

28802 X1

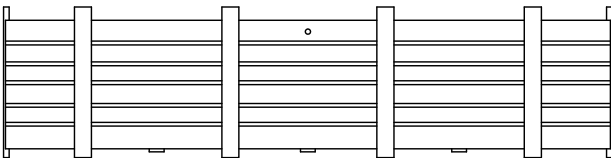

28804 X1

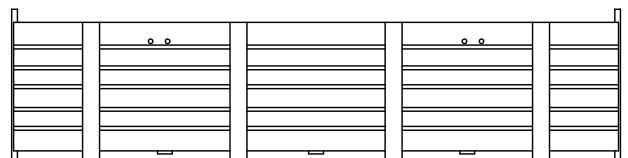

28805 X1

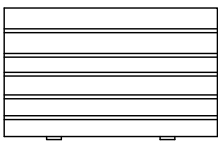

28803 X2



72019 X1

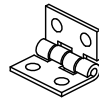

94013 X2

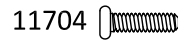

11704 M1.6x6 X2

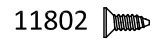

11802 ST1.4x4 X8

**LEAF SPRINGS**

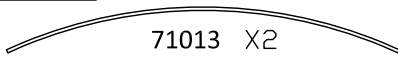

71013 X2

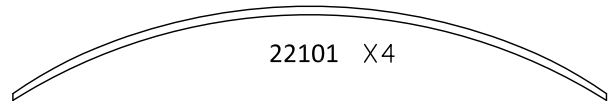

22101 X4

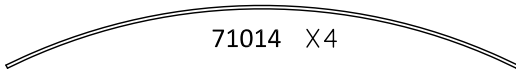

71014 X4

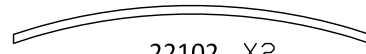

22102 X2

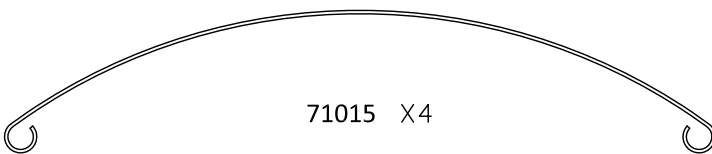

71015 X4



22104 X4

**BAG(A)**

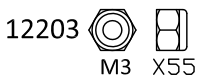

12203 M3 X55

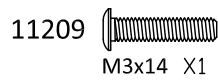

11209 M3x14 X1

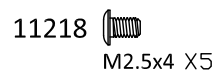

11218 M2.5x4 X5

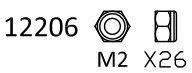

12206 M2 X26



11211 M3x18 X29

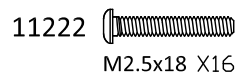

11222 M2.5x18 X16

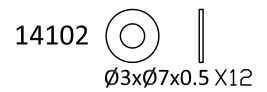

14102 Ø3xØ7x0.5 X12

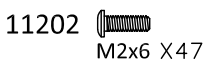

11202 M2x6 X47

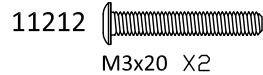

11212 M3x20 X2

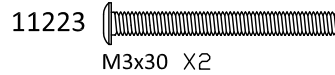

11223 M3x30 X2

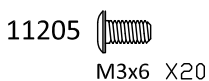

11205 M3x6 X20

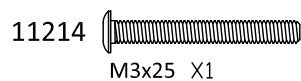

11214 M3x25 X1

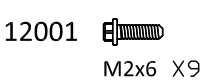

12001 M2x6 X9

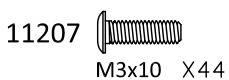

11207 M3x10 X44

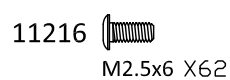

11216 M2.5x6 X62

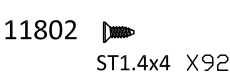

11802 ST1.4x4 X92

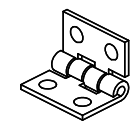

94013 X20

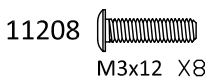

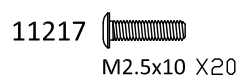

11208 M3x12 X8



11217 M2.5x10 X20

BAG(B)

11127  M2.5x7 X4

13001   $\phi 3 \times \phi 7.2 \times 0.5$  X2

91153   $\phi 4.3 \times \phi 7 \times 0.3$  X4

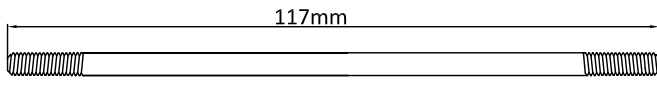

41102 X1

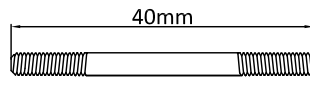

41121 X8

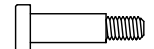

41308 X4



41803 X1

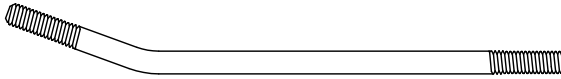

41471 X1

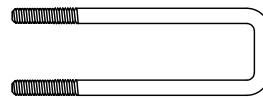

41473 X4

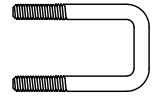

41474 X4

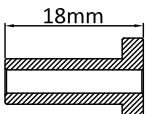

41475 X2



41478 X6

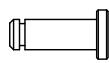

41479 X2

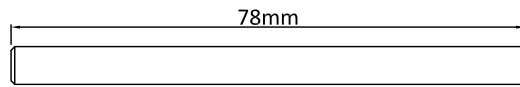

41480 X1



41656 X1

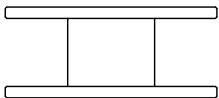

41481 X1



71159 X4



71230 X2



71231 X2



71232 X4

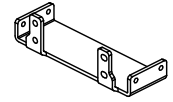

71233 X1

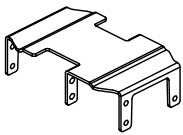

71234 X1

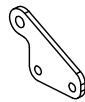

71235 X2

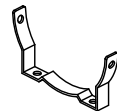

71236 X2

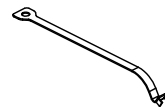

71237 X2

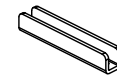

71238 X2

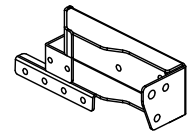

71239 X1

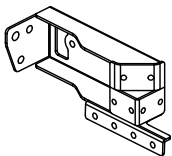

71240 X1

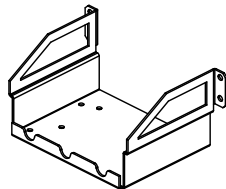

71241 X1

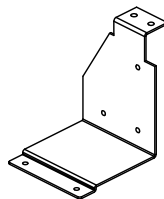

71242 X1

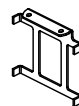

71243 X2



71244 X1



71245 X1



71246 X1



71250 X2



71251 X2



71252 X1

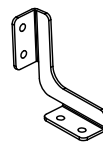

71253 X6

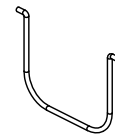

71254 X14

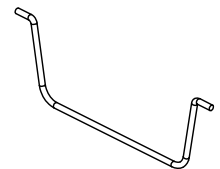

71255 X2

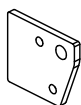

71273 X2

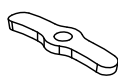

72027 X4



73082 X2



73083 X2

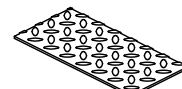

73084 X2

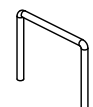

94060 X2

**BAG(C)**

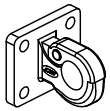

30104 X1



30402 X4



30411 X4



34301 X2

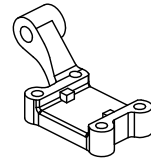

34302 X2

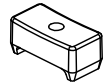

34303 X2

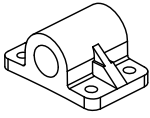

34305 X2

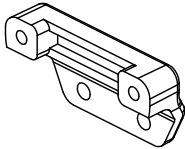

34306 X2

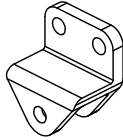

34401 X4

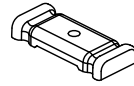

34402 X4

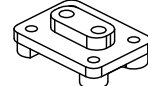

34403 X4

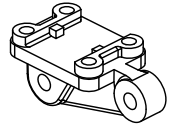

34404 X4

**BAG(D)**

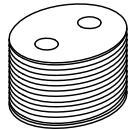

50038 X4

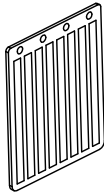

50022 X4

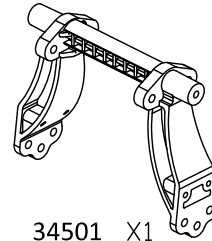

34501 X1

**No.2001**

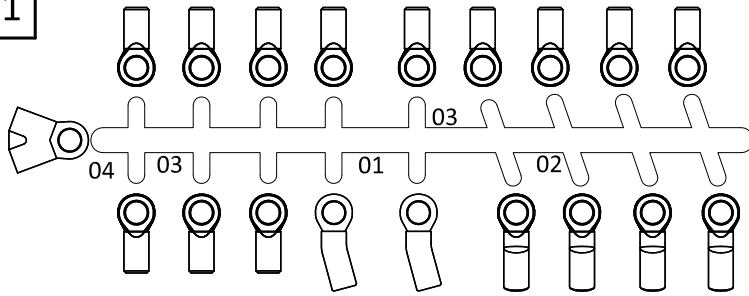

2001 X2

41336 X18

**No.2127**

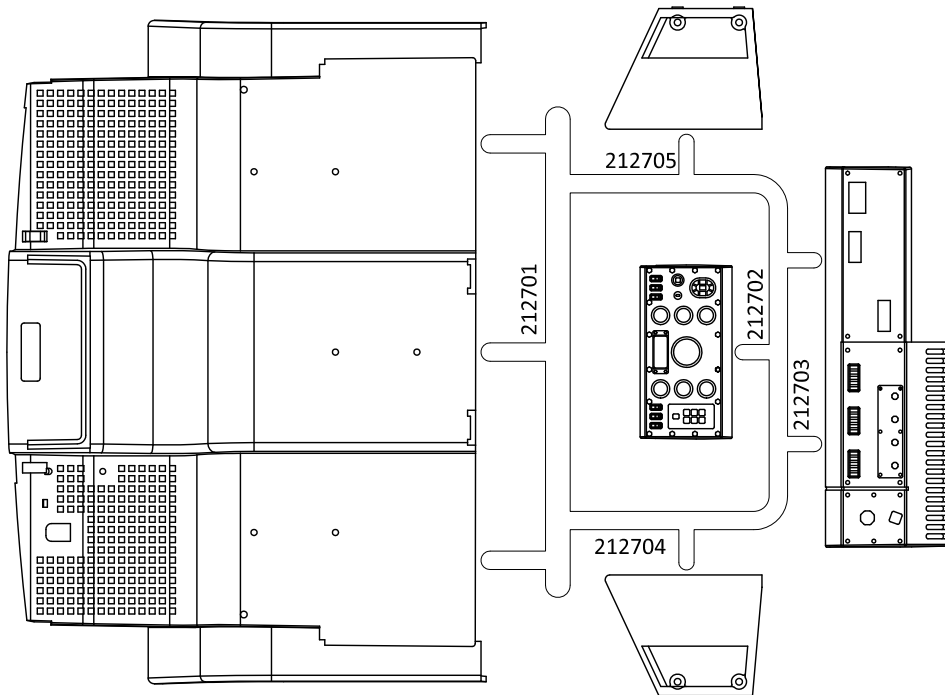

2127 X1

No.2128

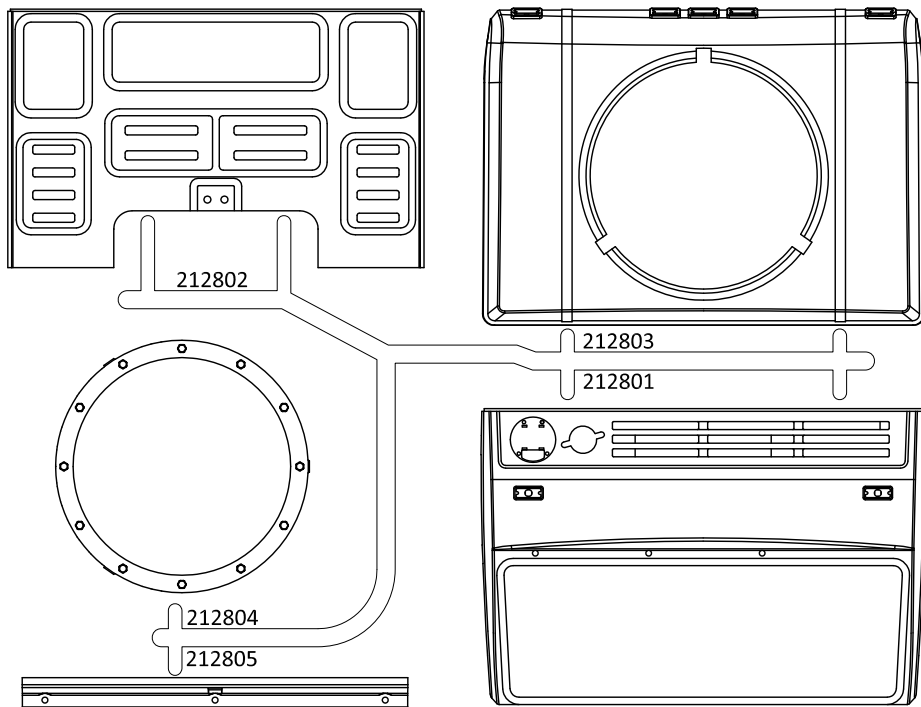

2128 X1

No.2129

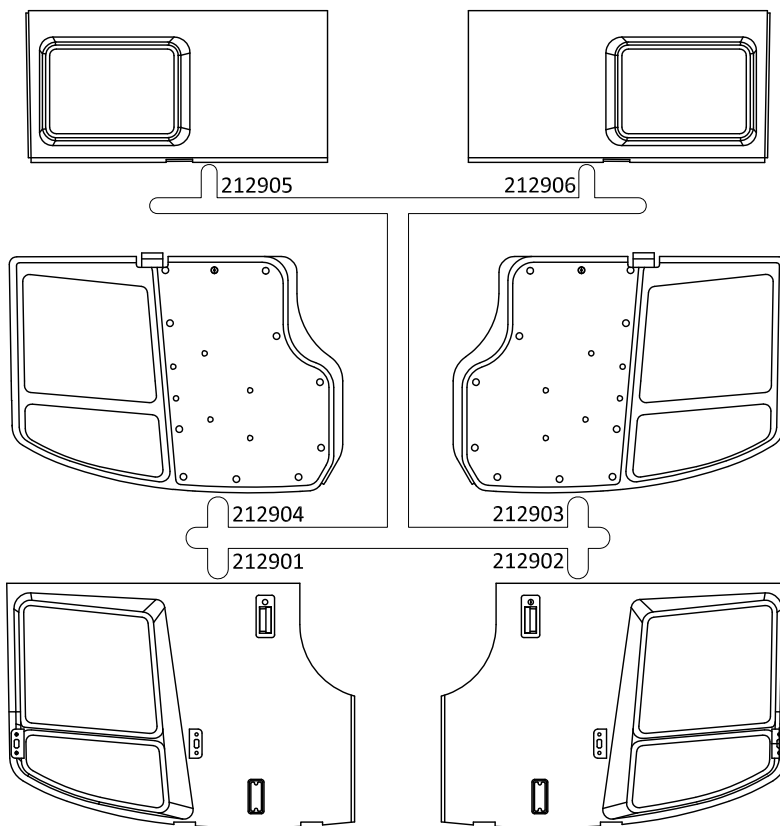

2129 X1

No.2130

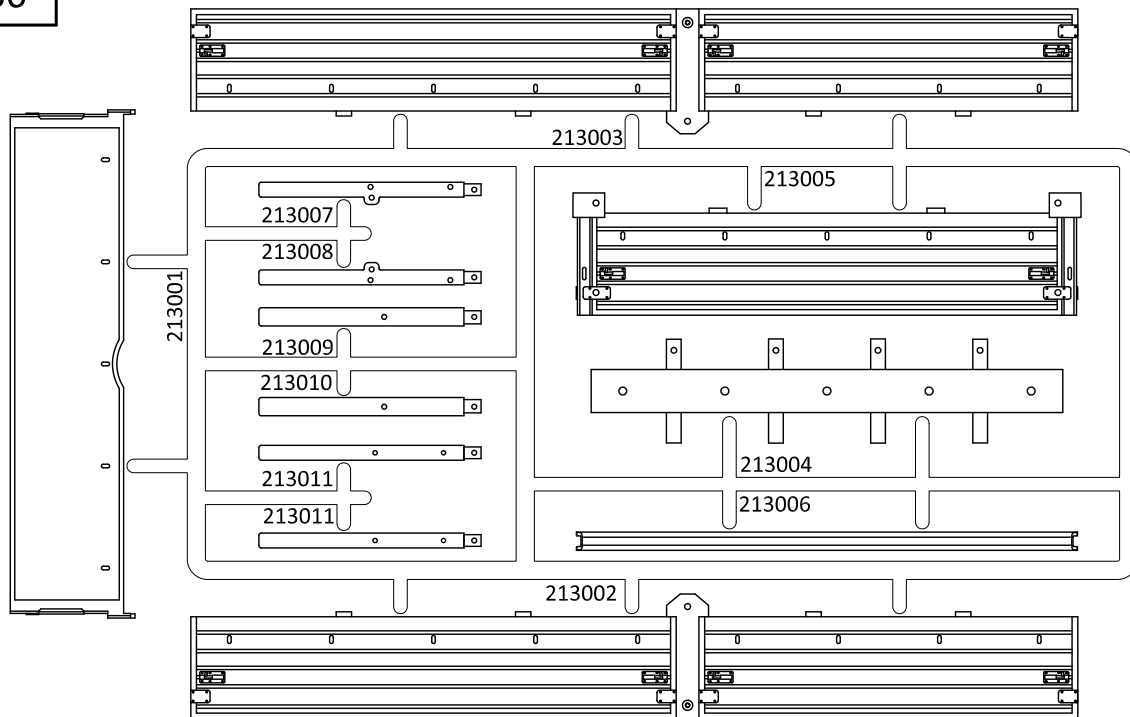

2130 X1

No.2131

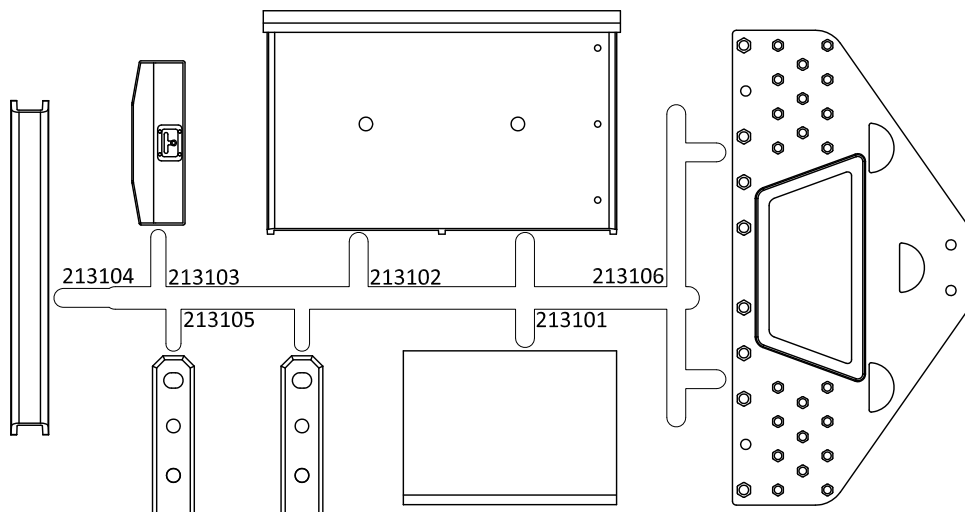

2131 X2

No.2132

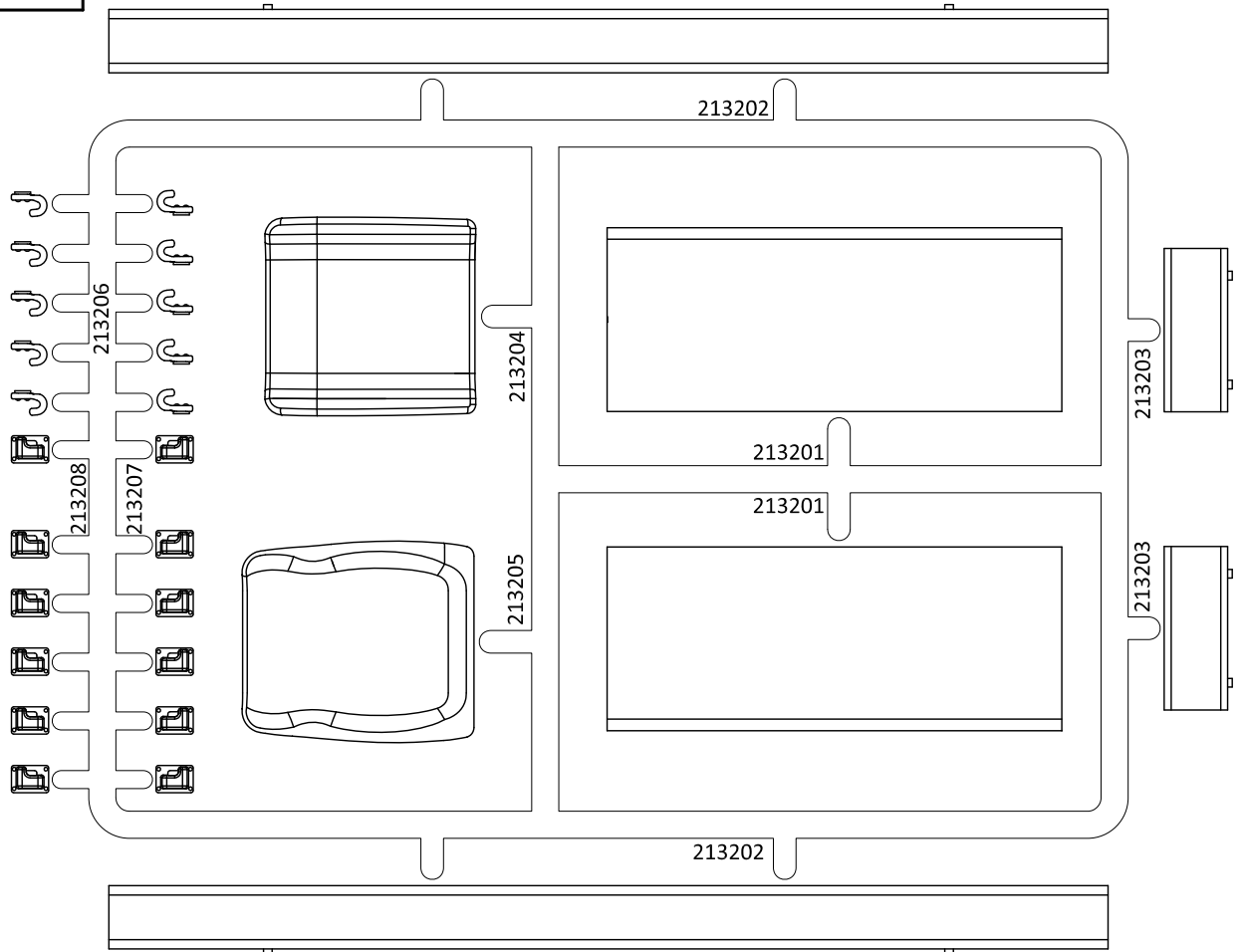

2132 X3

No.2133

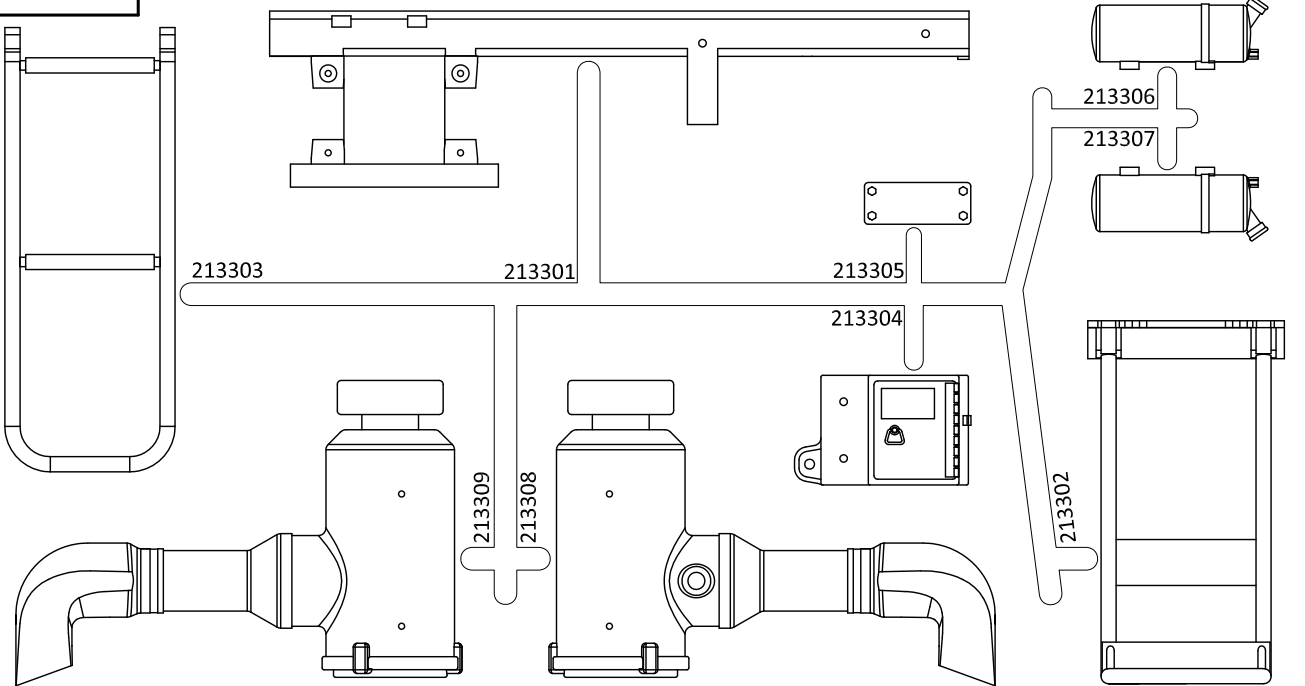

2133 X1

No.2134

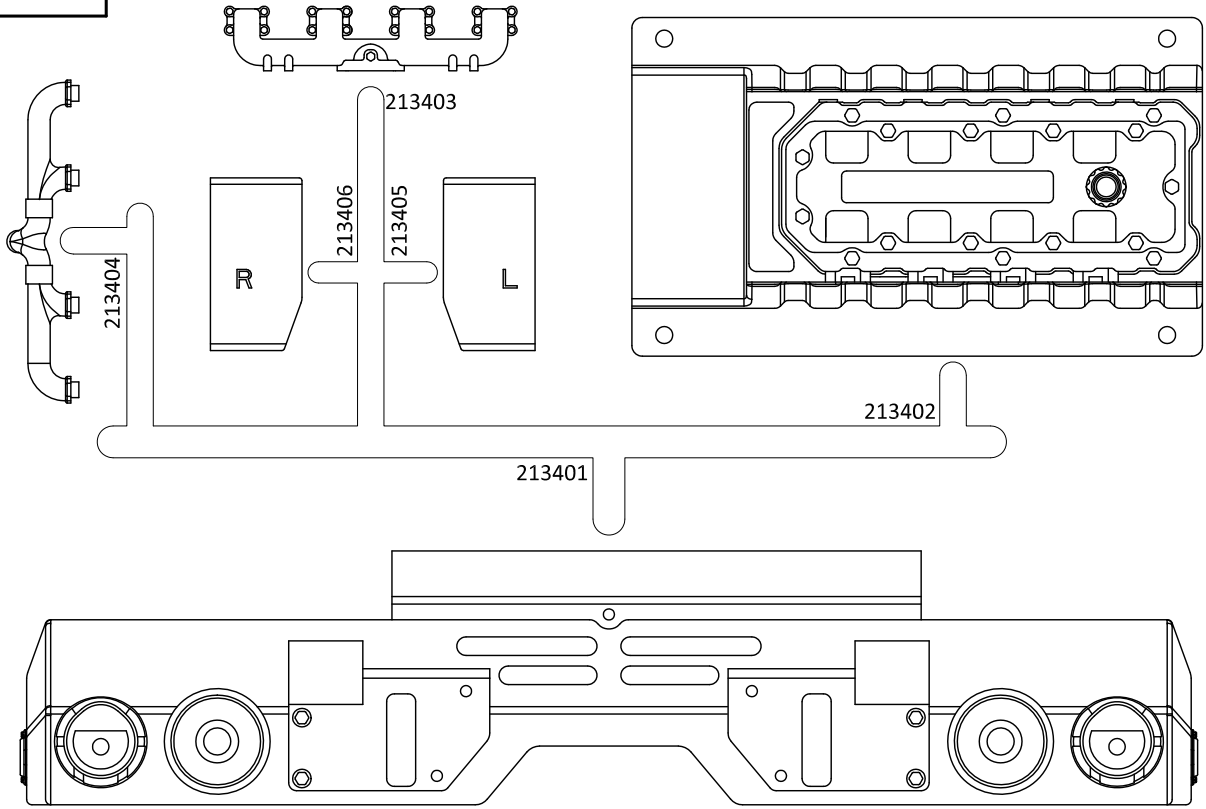

2134 X1

No.2135

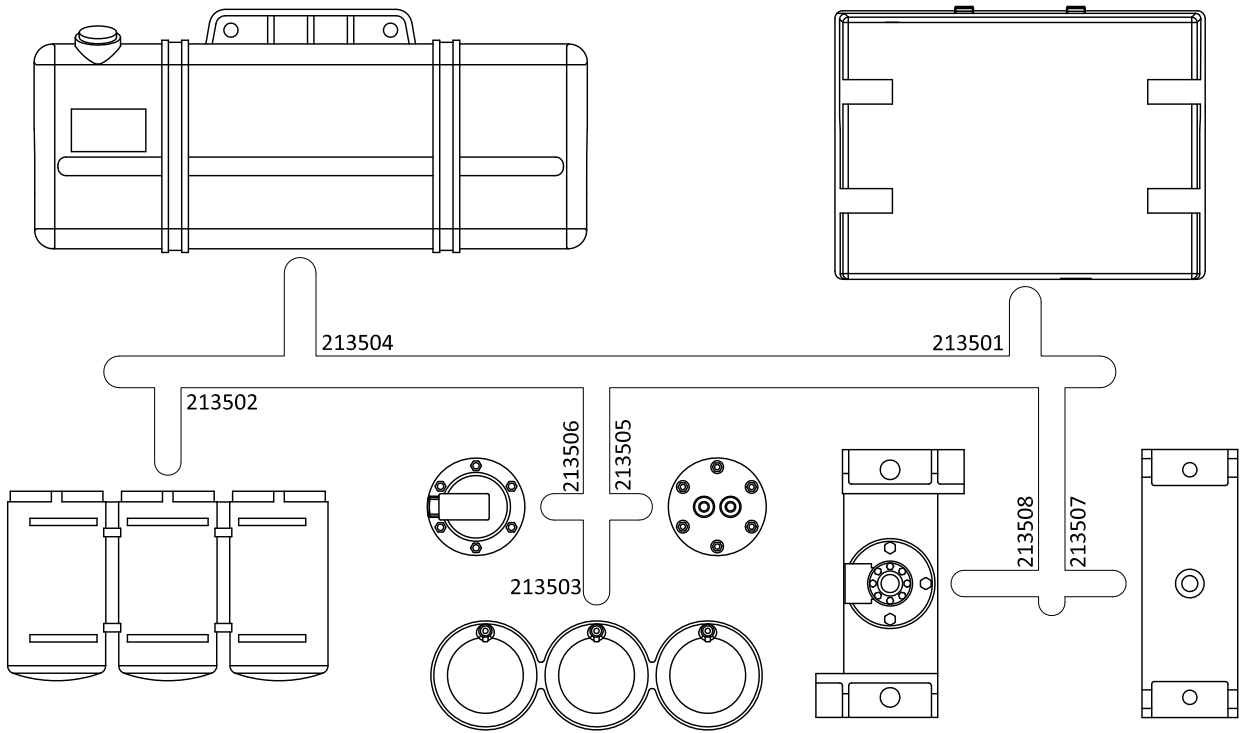

2135 X1

No.2136

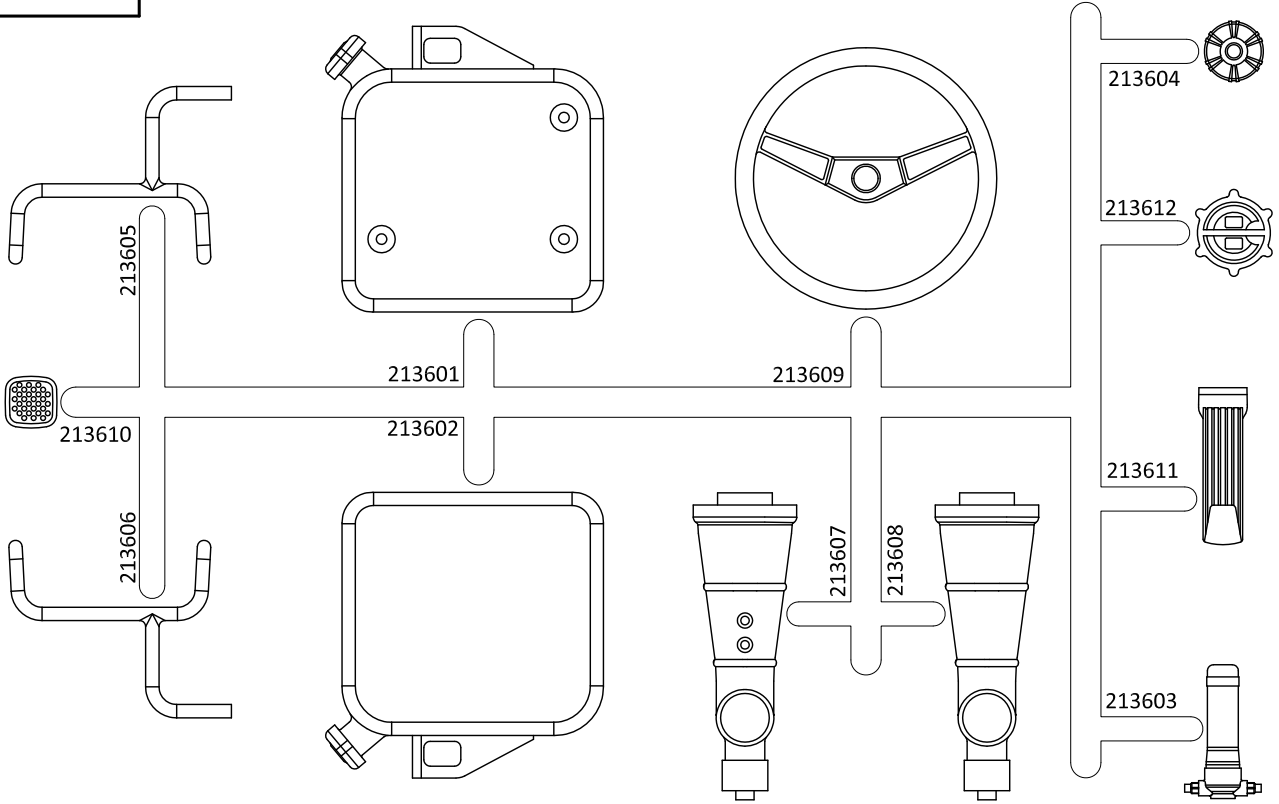

2136 X1

No.2137

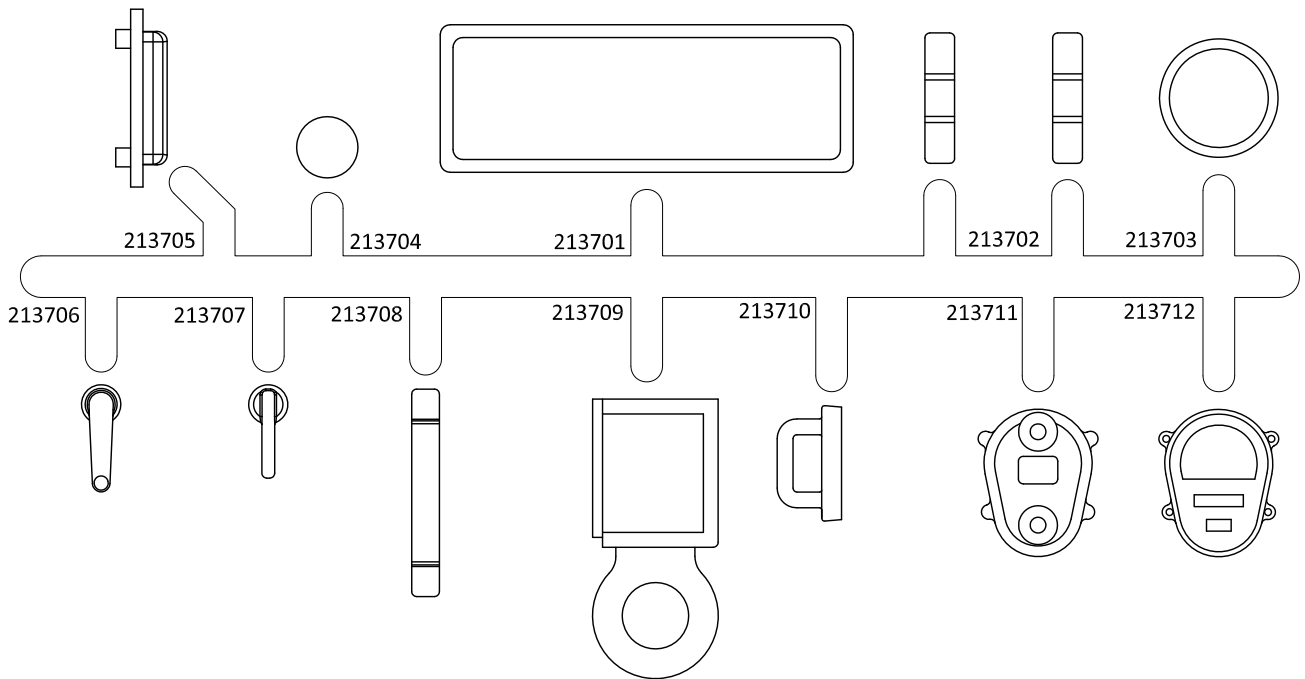

2137 X2

No.2138

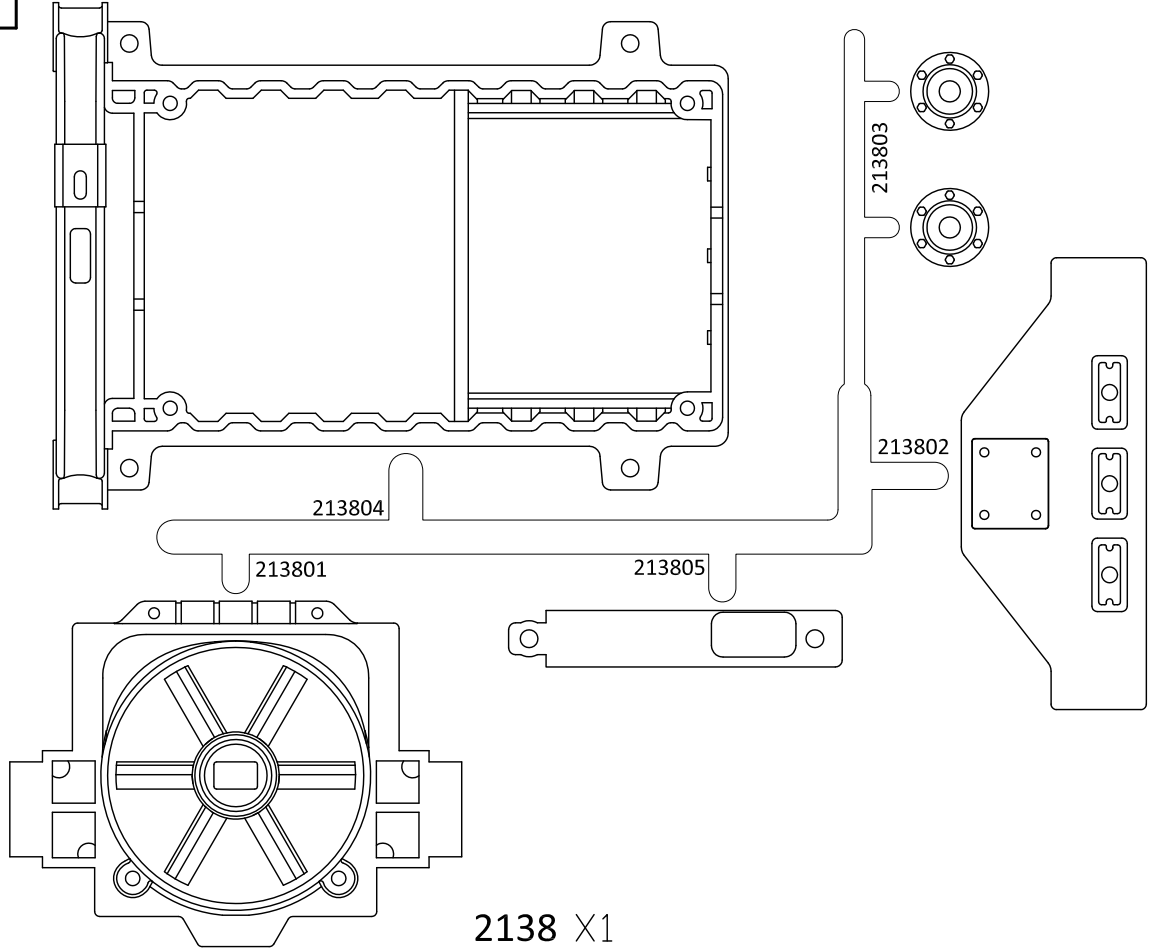

No.2139

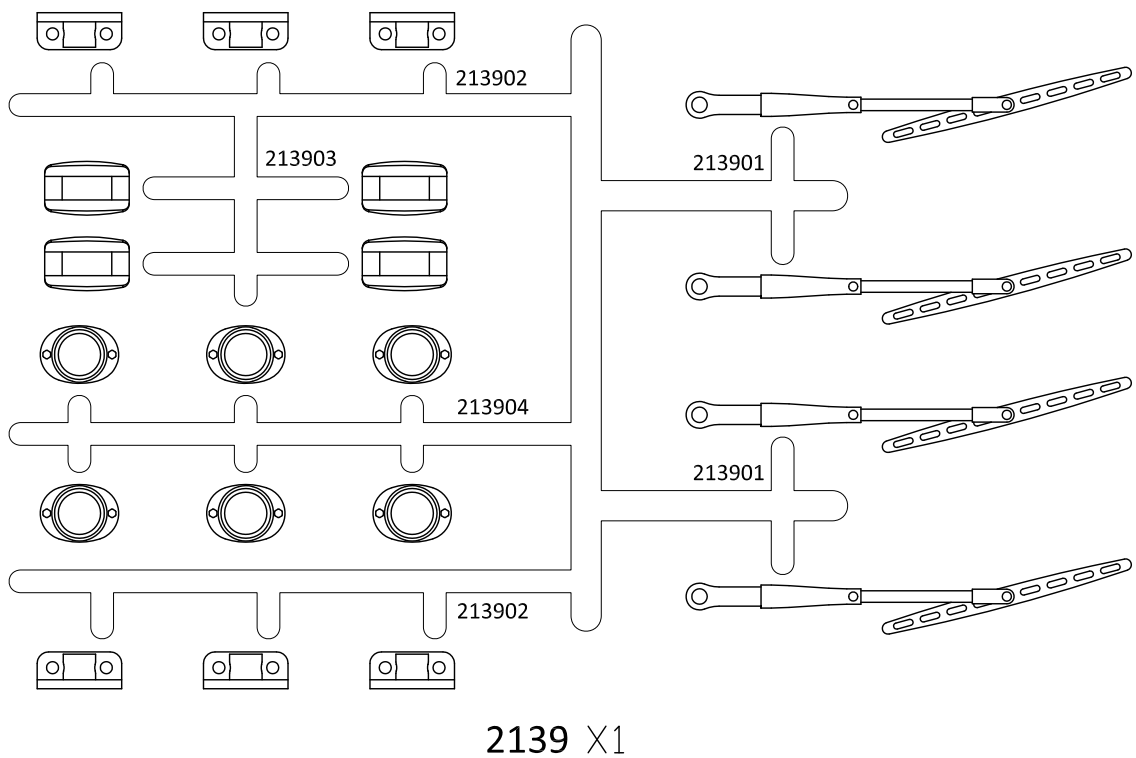

No.2140

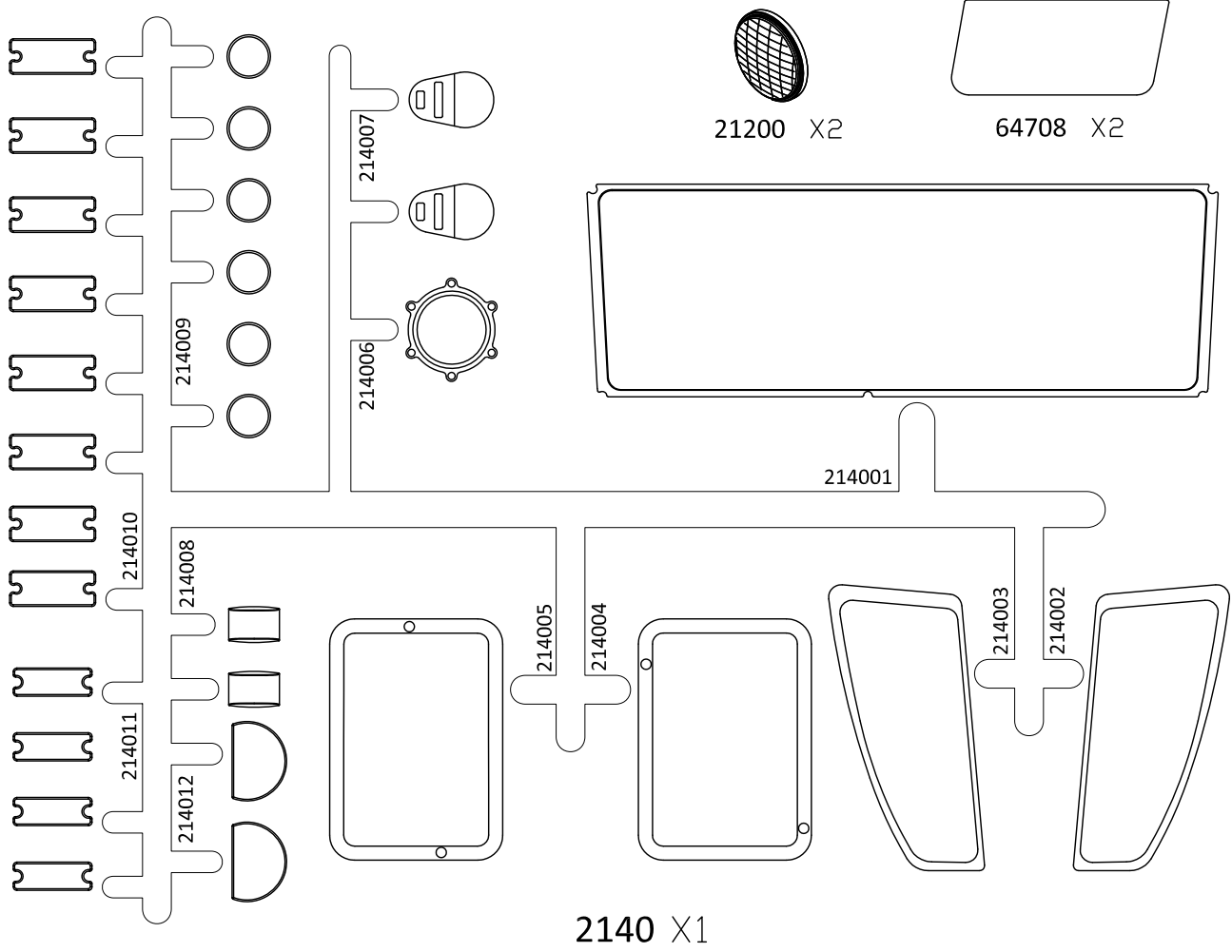

GIFT

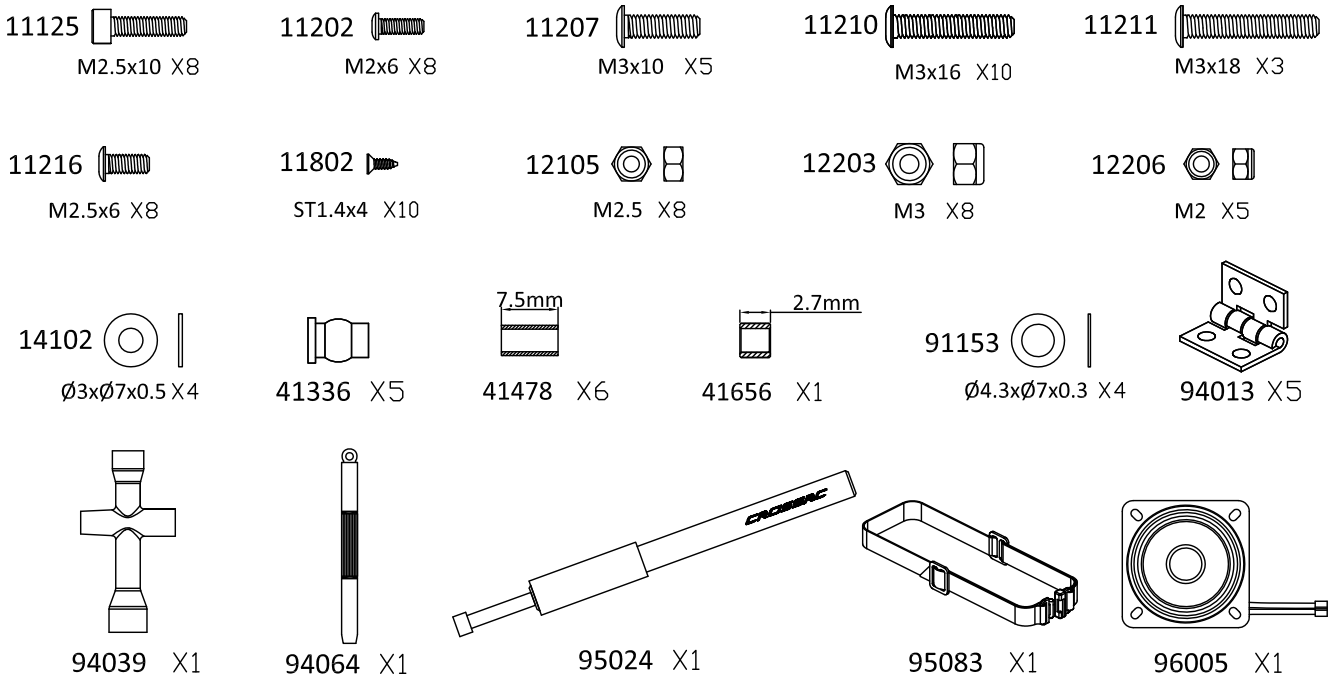

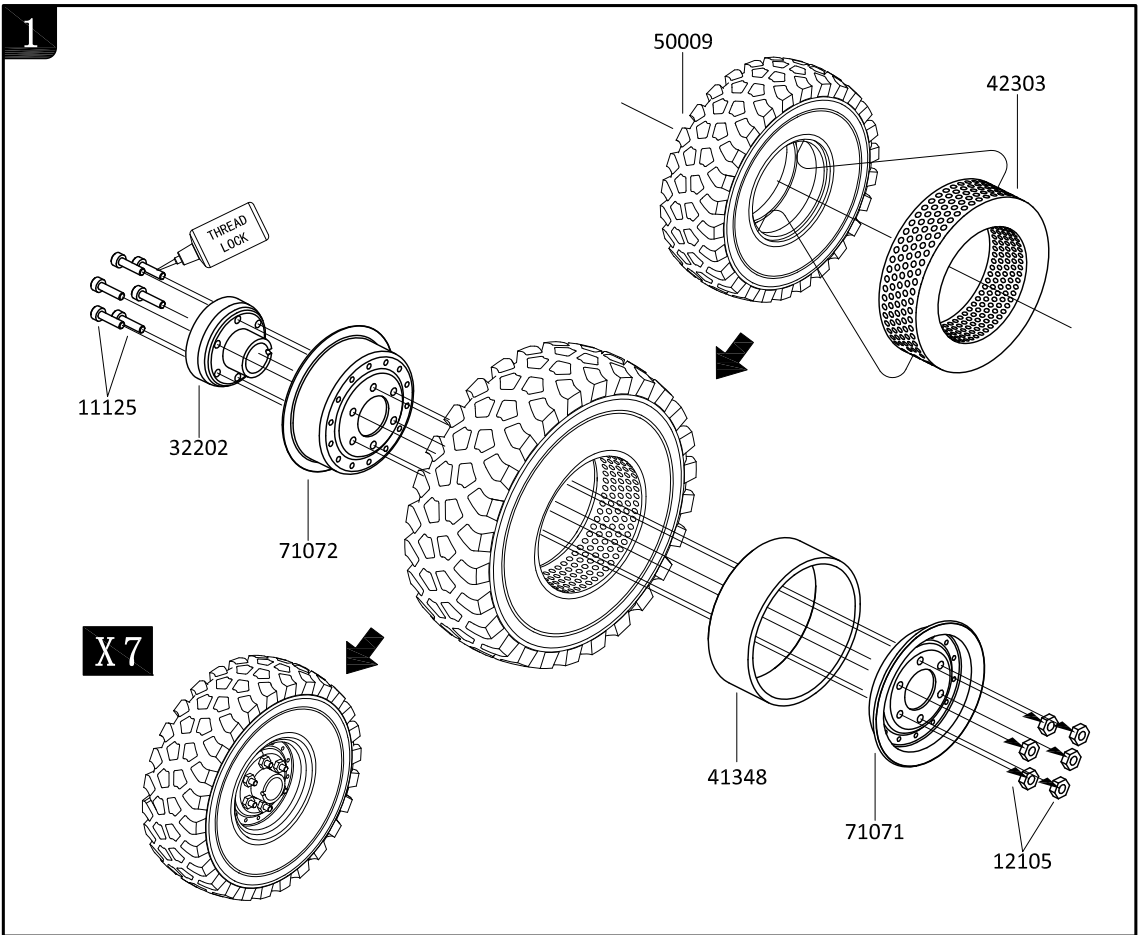

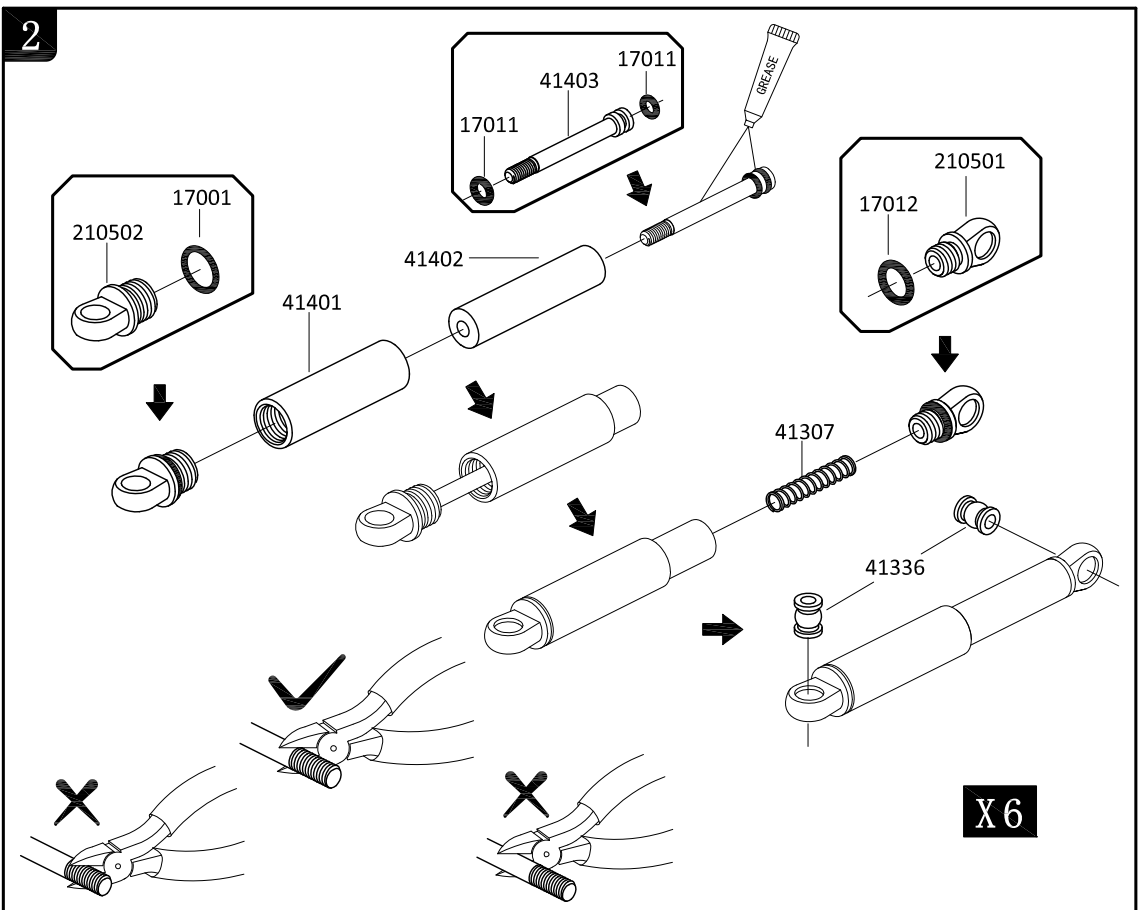

- 12105 M2.5 X42
- 11125 M2.5x10 X42
- 11119 M2.5x16 X2



- 17001  $\phi 8 \times \phi 6 \times 1.0$  X6
- 17011  $\phi 5 \times \phi 2 \times 1.5$  X12
- 17012  $\phi 6 \times \phi 4 \times 1$  X6

3

13003  |  
 $\phi 2.5 \times \phi 6 \times 0.4 \times 2$

15003  |  
 $\phi 5 \times \phi 10 \times 4 \times 4$

41446  |  
 $\phi 5.1 \times \phi 8 \times 1.5 \times 2$

Adjust the backlash with the Shims.

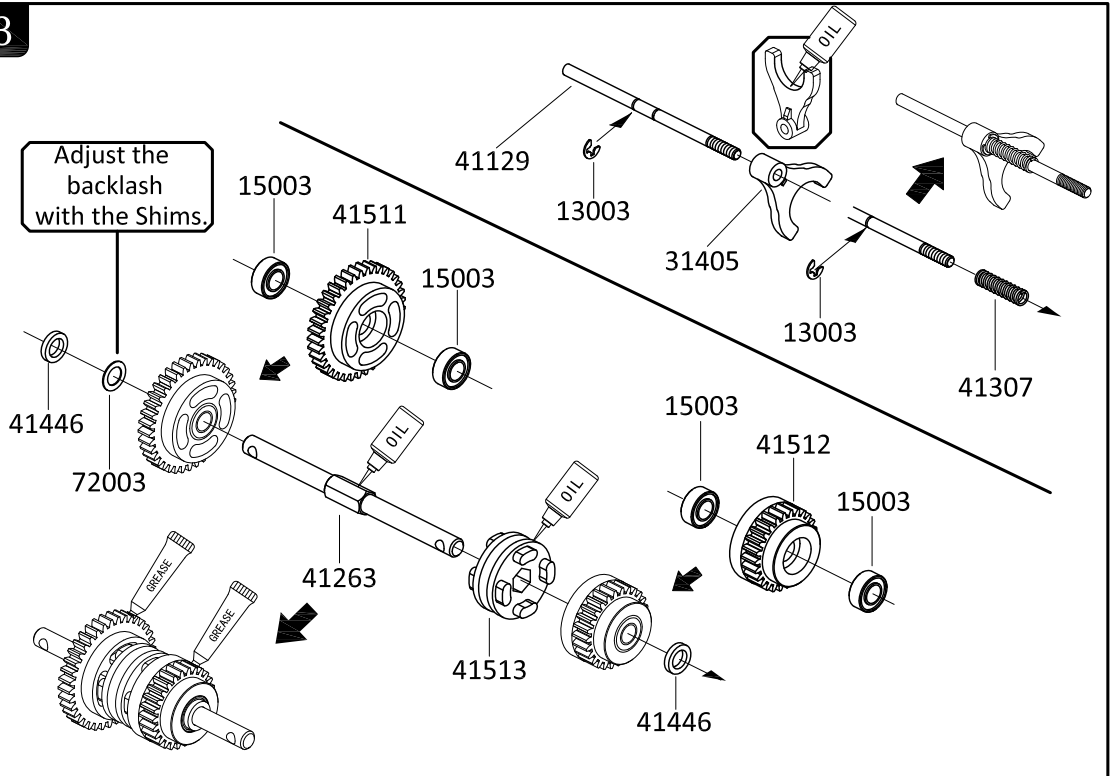

4

11219   
 M3x4 X3



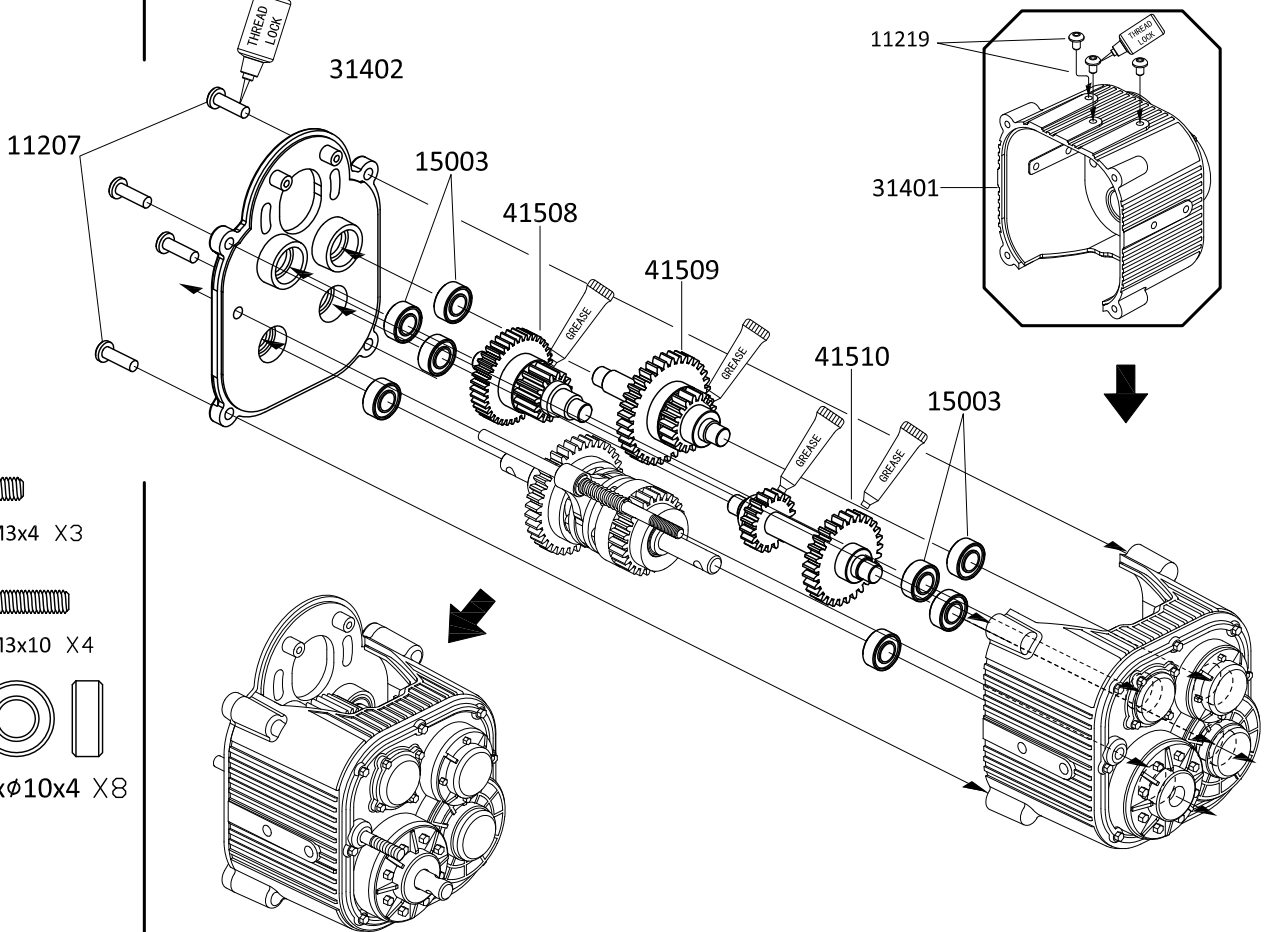

11207   
 M3x10 X4

15003  |  
 $\phi 5 \times \phi 10 \times 4 \times 8$



5

Use a trip of the note book paper to set gear backlash between spur gear and moto gear.  
If the space is not correct, the spur gear will be damaged.

- 11401  M3x4 X1
- 11102  M2x6 X2
- 11106  M3x8 X2
- 14102   $\phi 3 \times \phi 7 \times 0.5$  X2

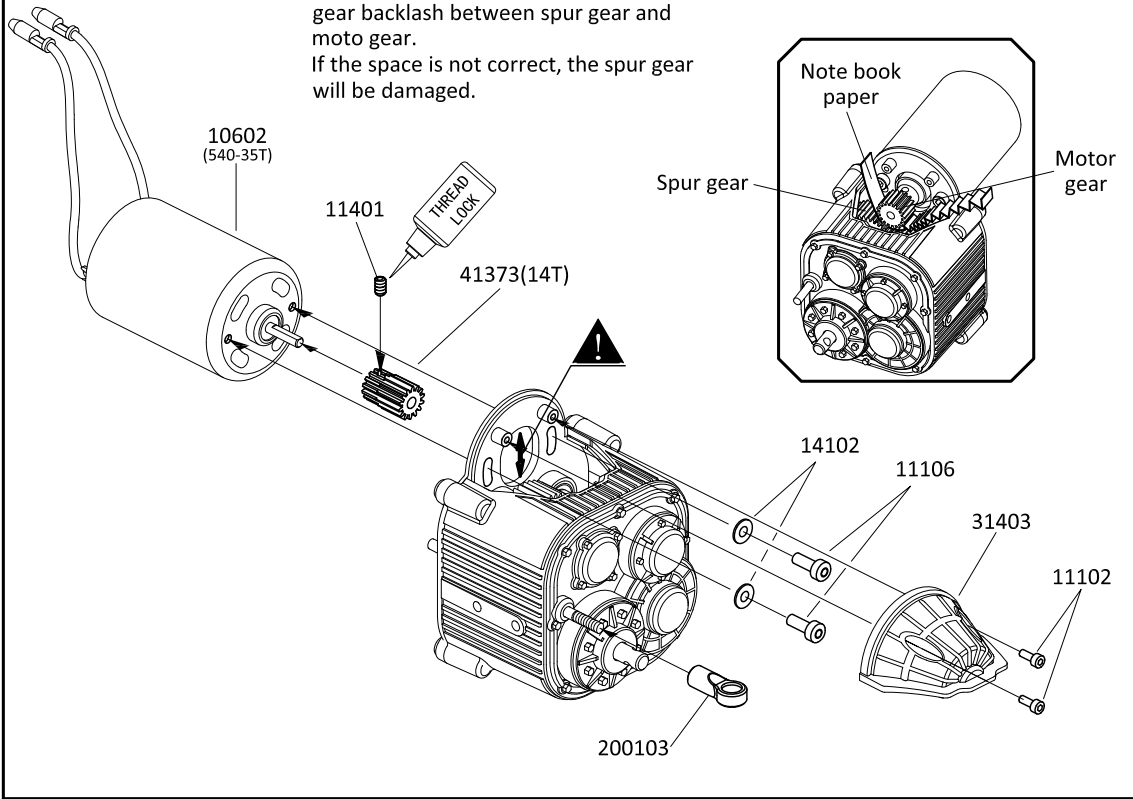

6

**NOTE:**  
Get power test after assembly finish and adjust gear meshing clearance for make sure gear box running smooth without noise, then process to following assembly go on.

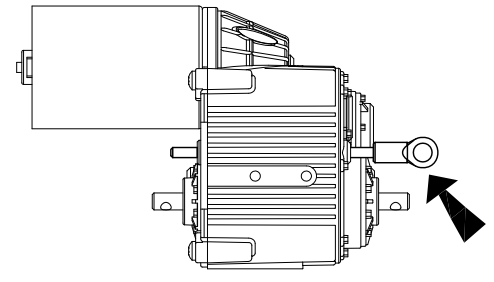
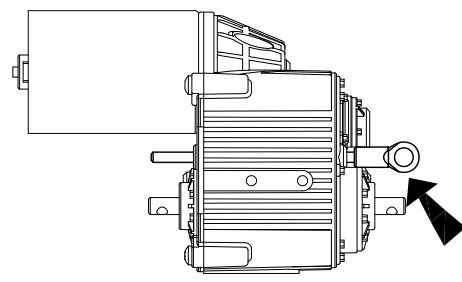
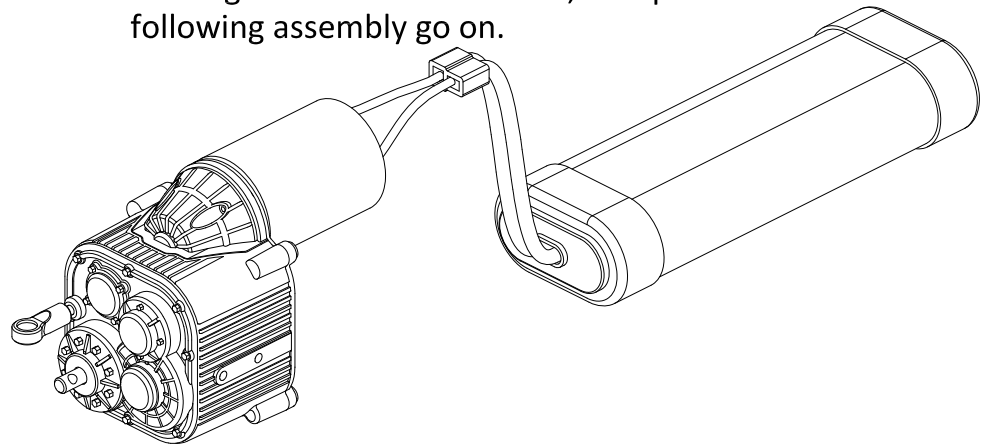

1st Gear (Low speed)

2nd Gear (High speed)

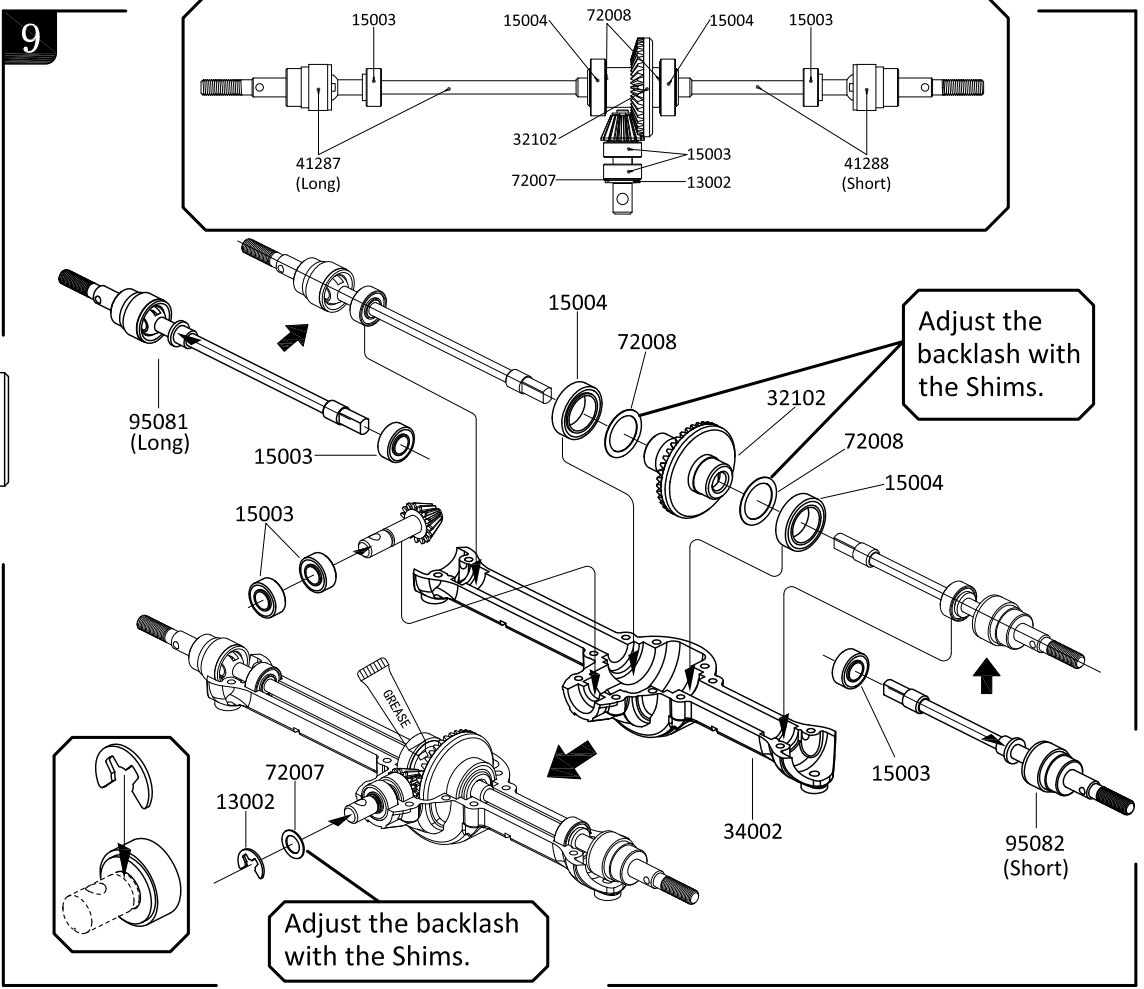
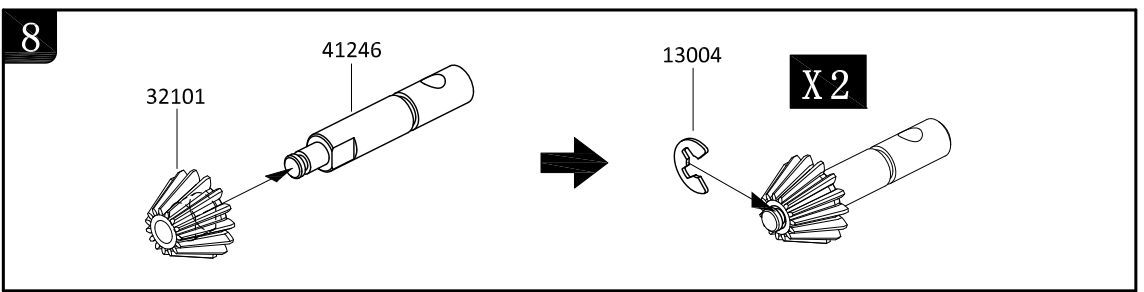
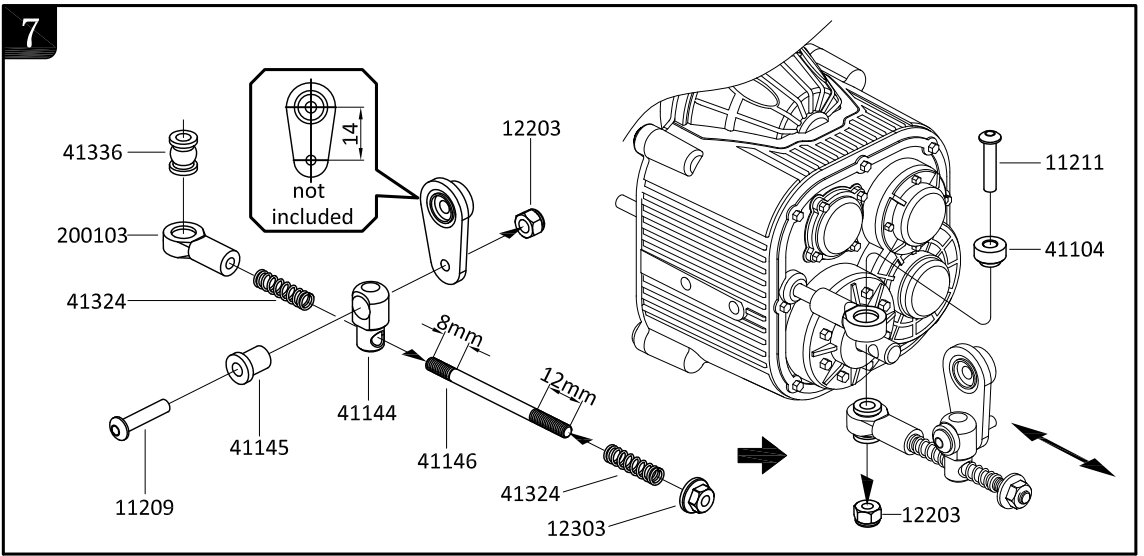

10

11116   
M2.5x12 X10

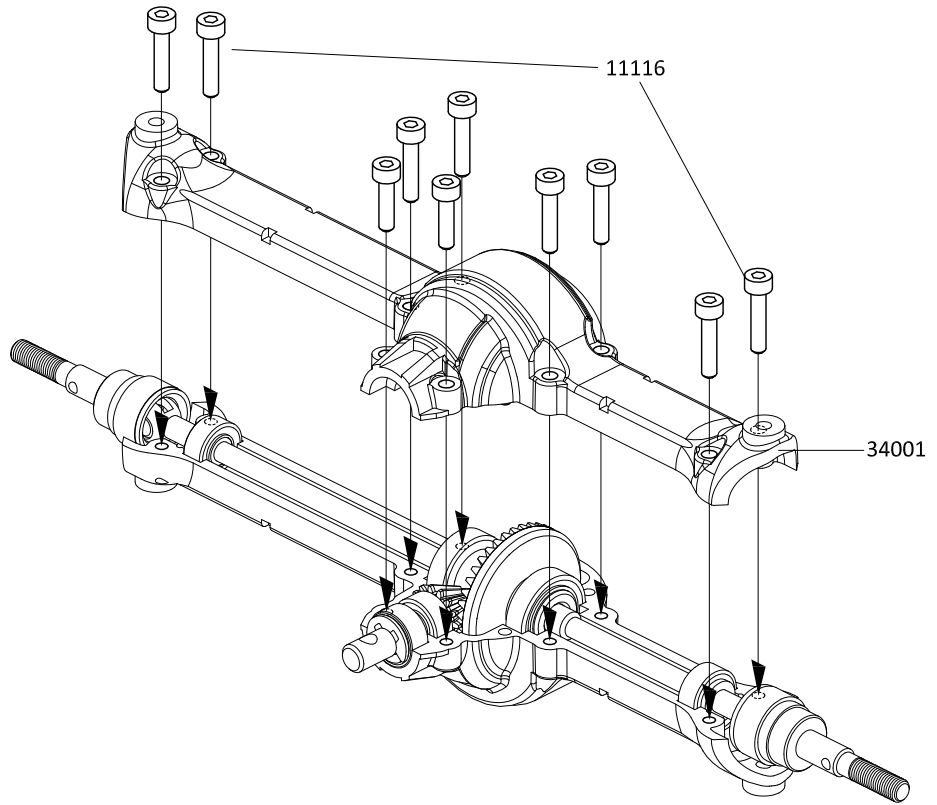

11

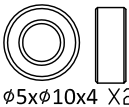

11207   
M3x10 X4

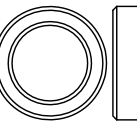
15003   
ø5xø10x4 X2

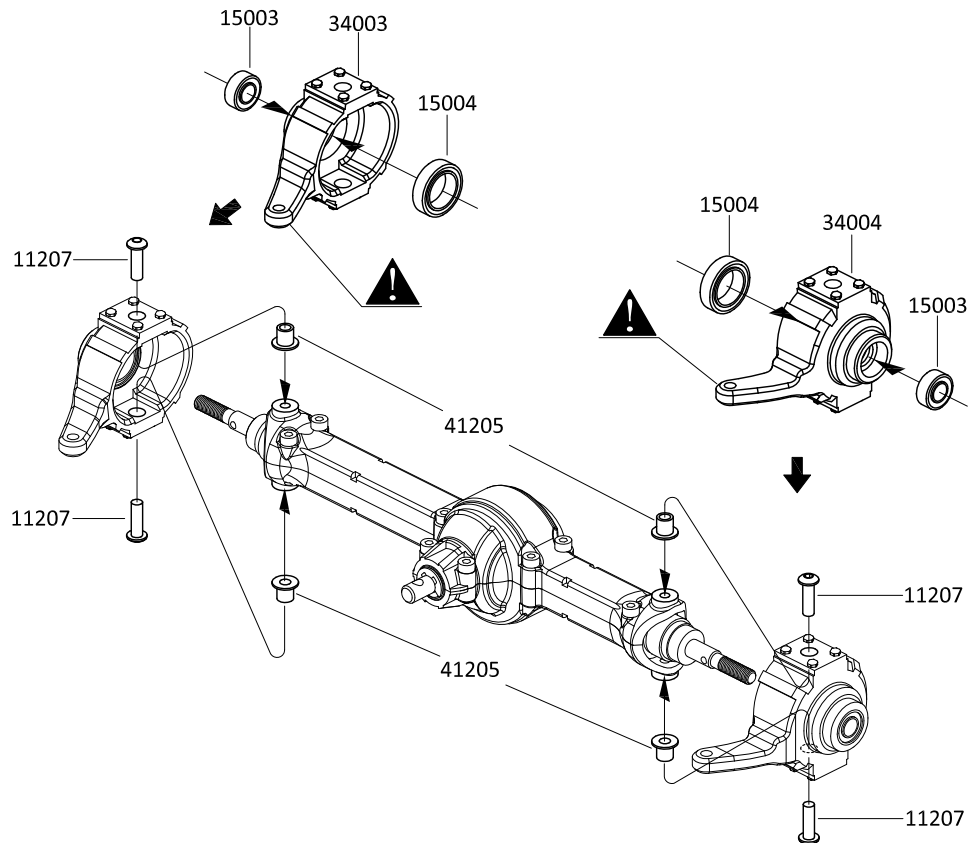
15004   
ø10xø15x4 X2



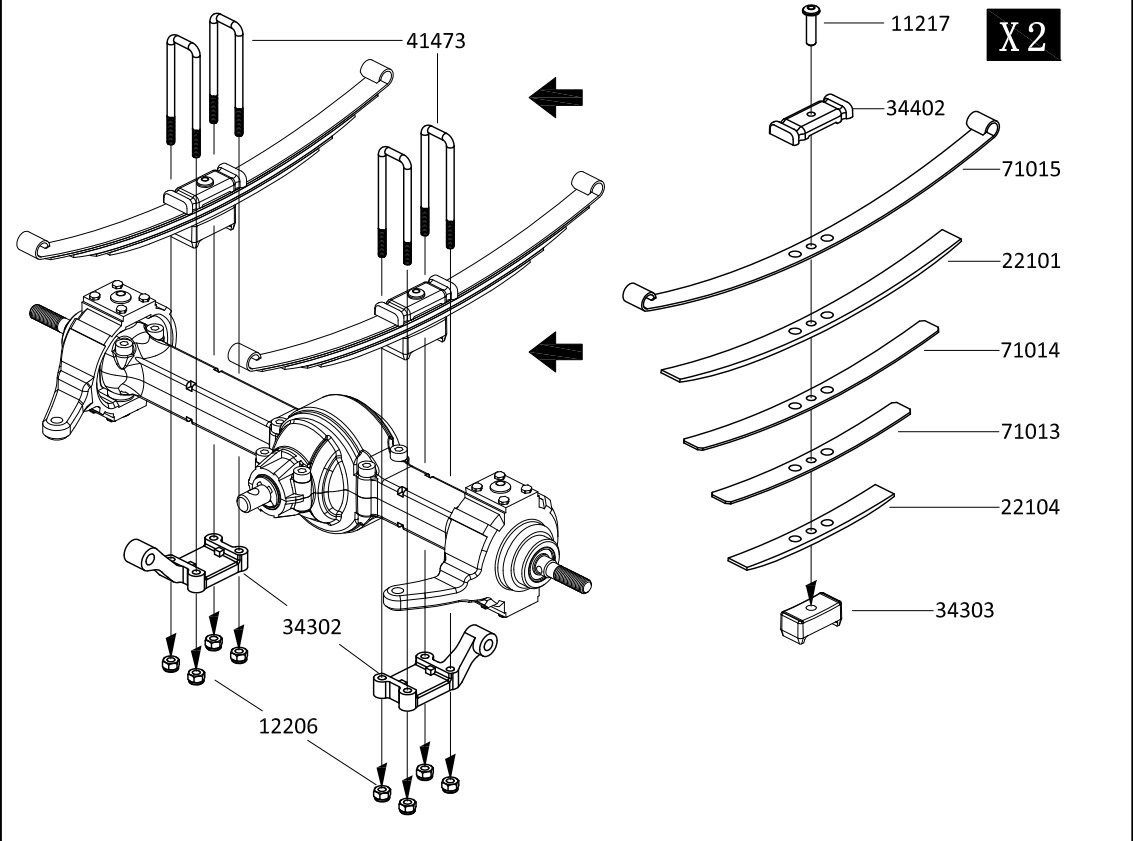

12

- 12206  M2 X8
- 11217  M2.5x10 X2



13

- 12203  M3 X2
- 11211  M3x18 X1
- 11214  M3x25 X1

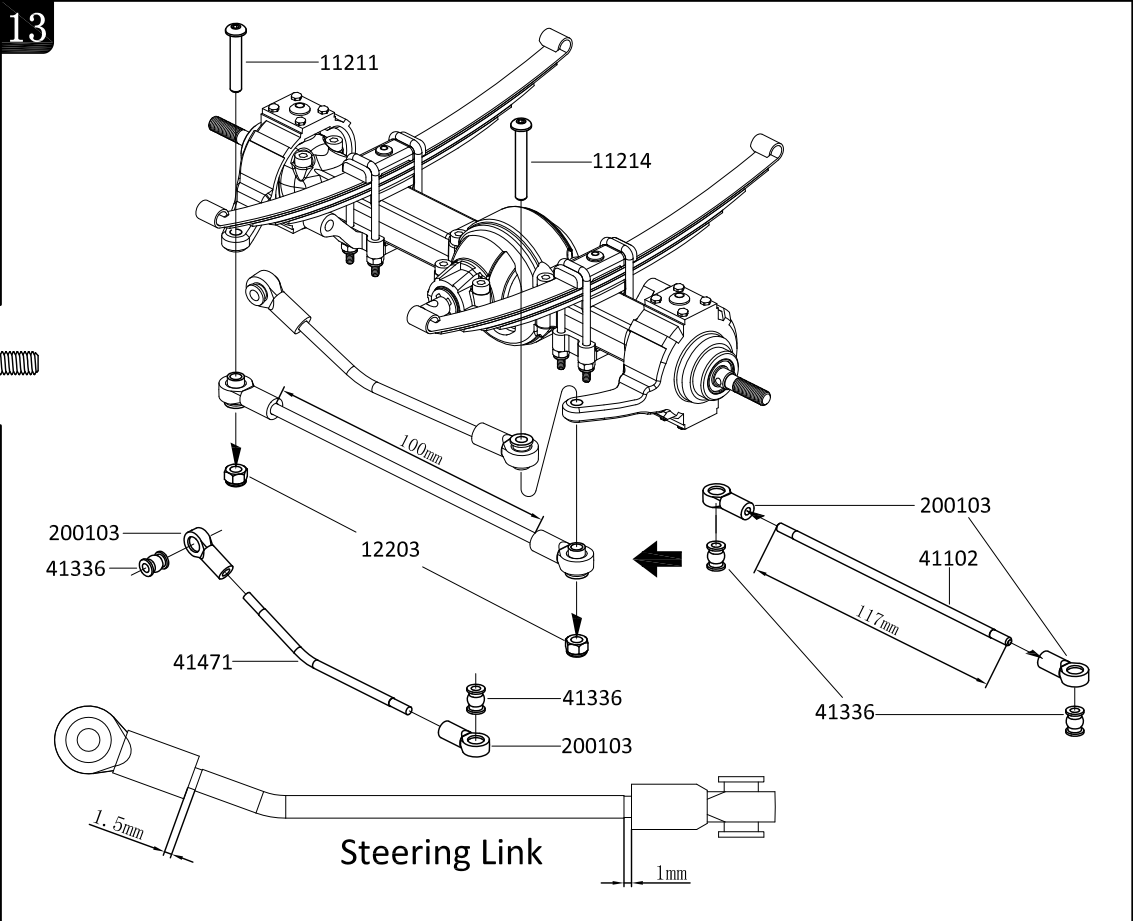

14

11601   
M3x16 X1

13004   
φ2xφ5.5x0.4 X1

15003   
φ5xφ10x4 X1

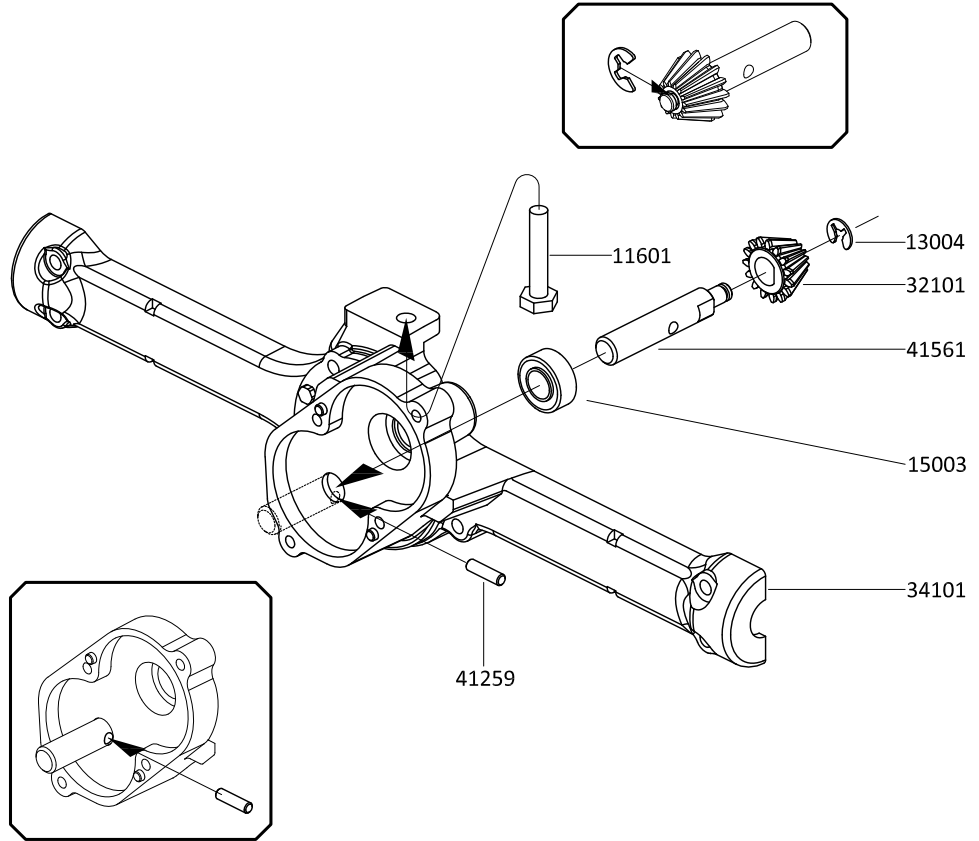

15

11116   
M2.5x12 X5

11119   
M2.5x16 X3

15003   
φ5xφ10x4 X2

15004   
φ10xφ15x4 X2

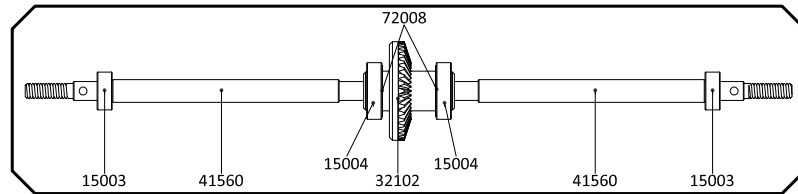

Adjust the backlash with the Shims.

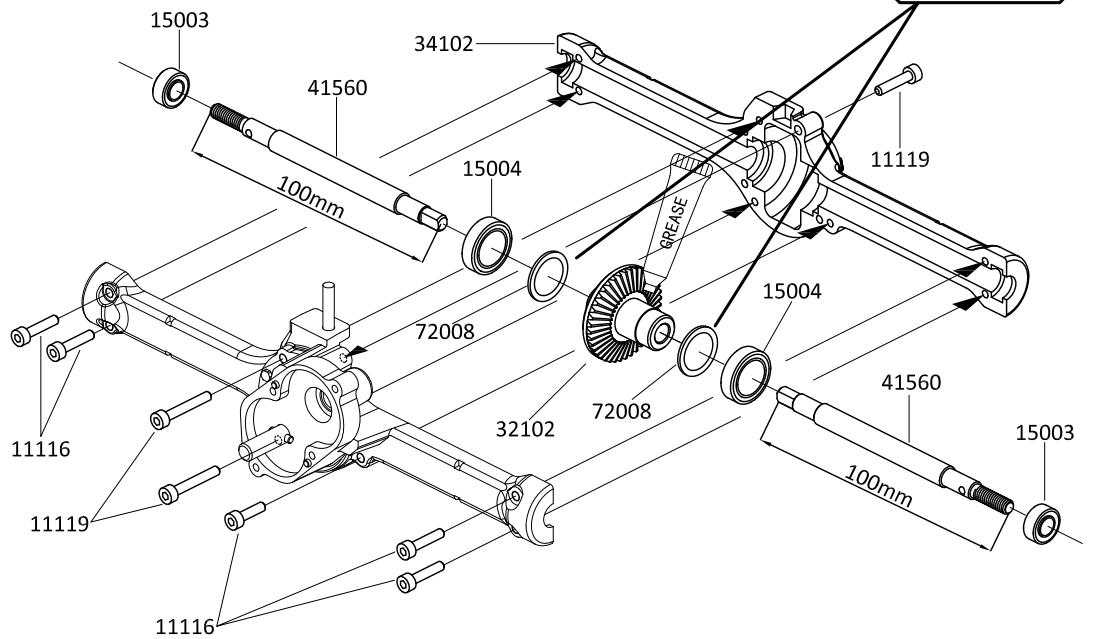

16

11116   
M2.5x12 X4

15003   
ø5xø10x4 X3

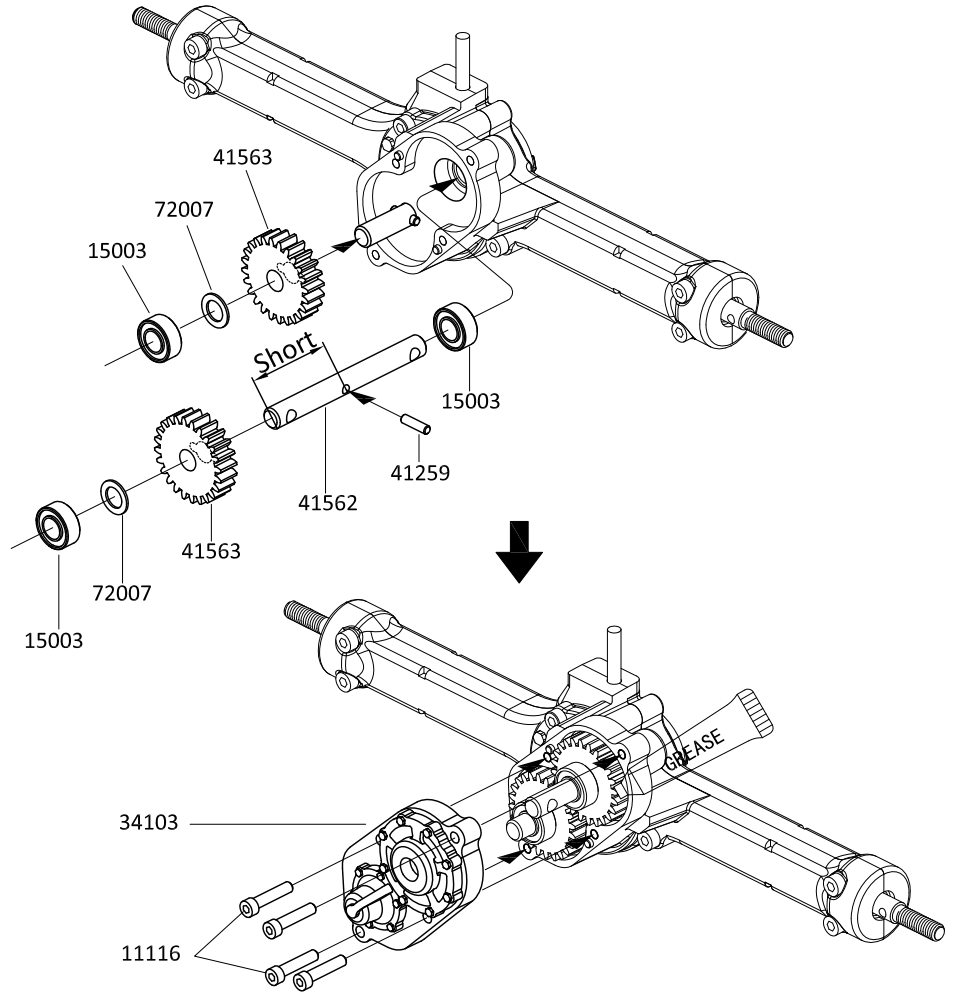

17

11601   
M3x16 X1

13002   
ø3.8xø9.2x0.6 X1

15003   
ø5xø10x4 X2

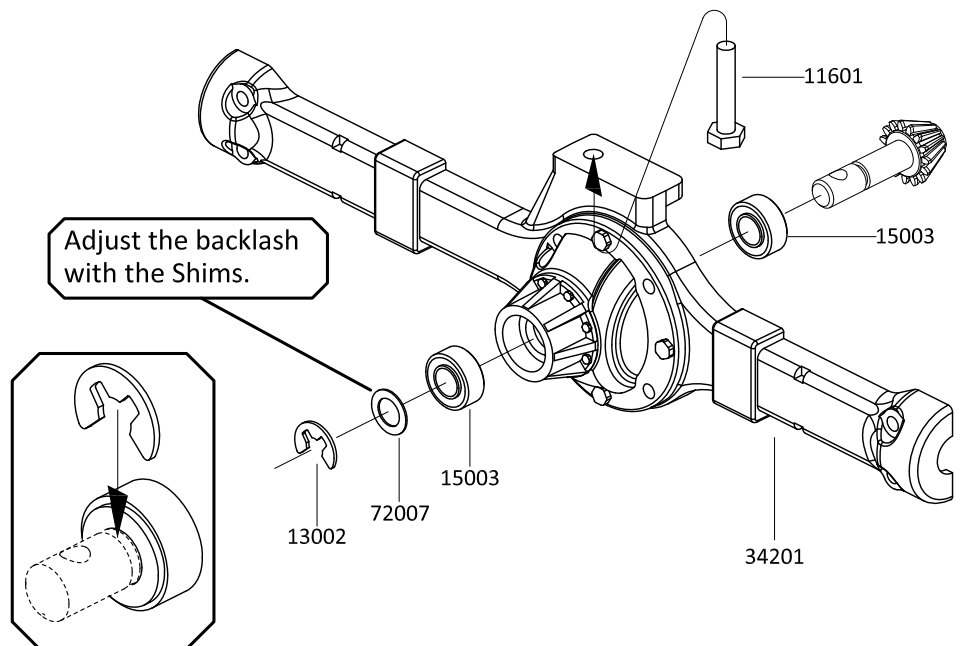

18

11116  M2.5x12 X4

11119  M2.5x16 X4

15003   $\phi 5 \times \phi 10 \times 4$  X2

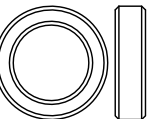
15004   $\phi 10 \times \phi 15 \times 4$  X2

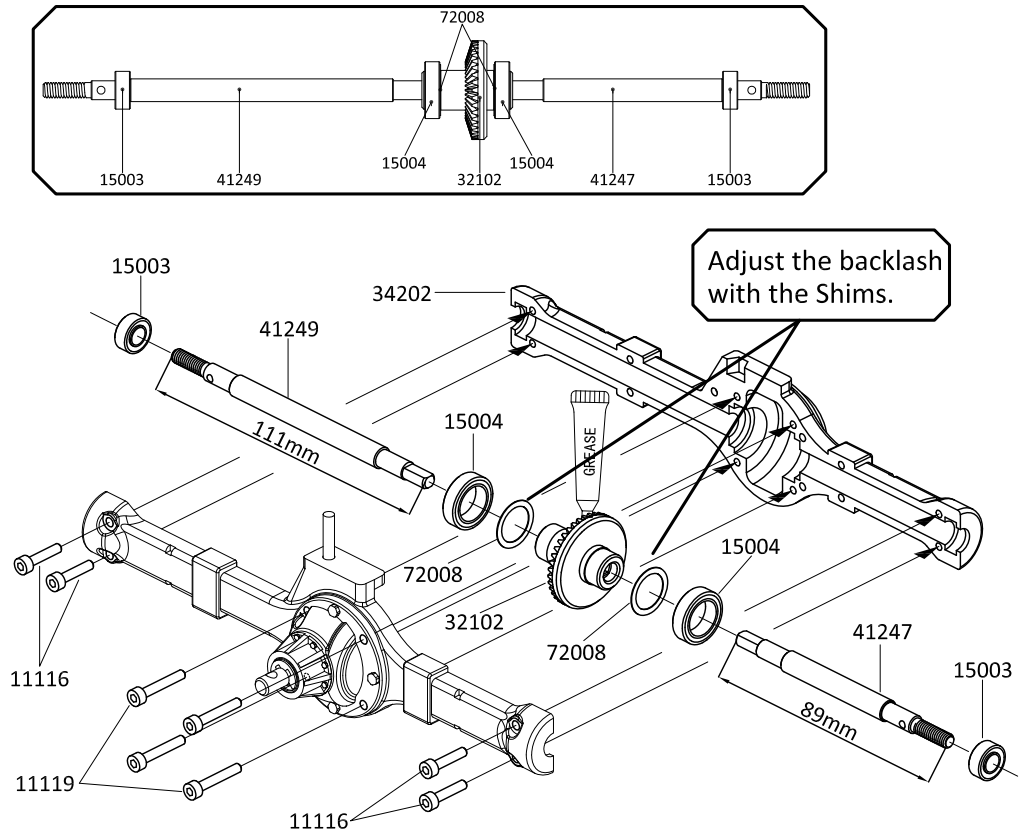

19

11208  M3x12 X8

12206  M2 X8

11217  M2.5x10 X2

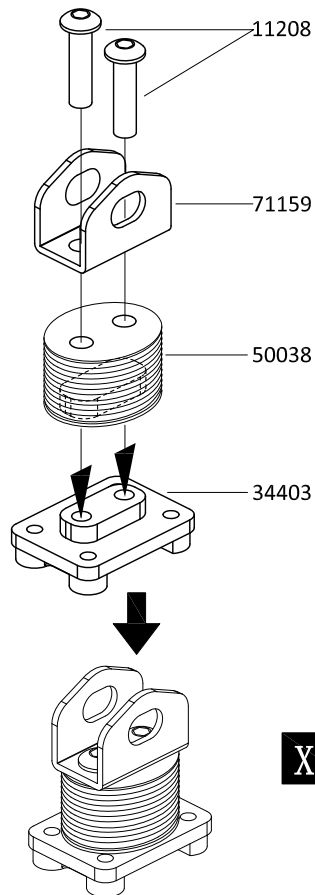

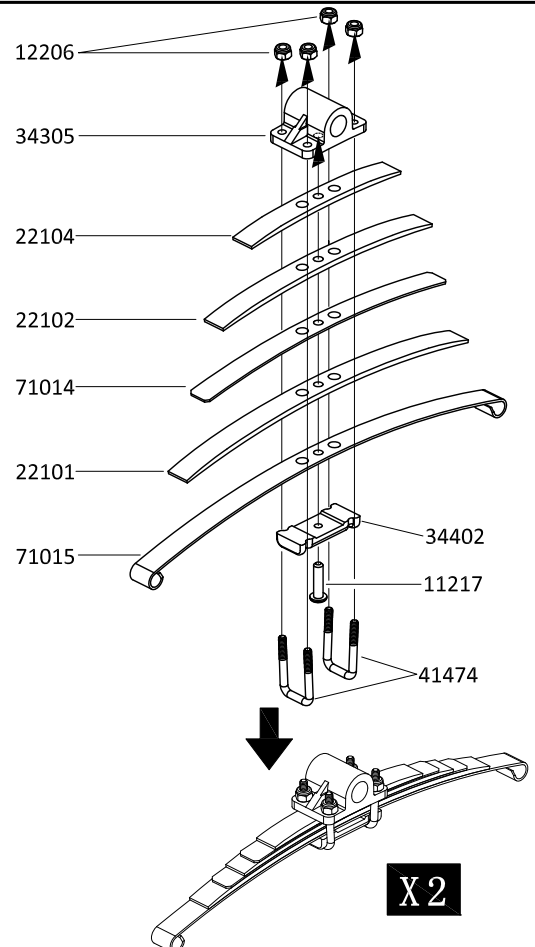

20

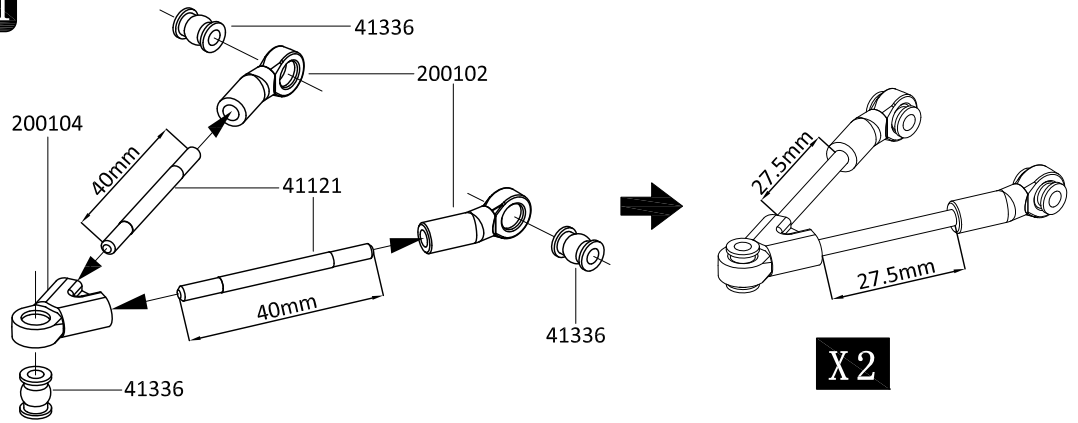

21



22

12203    
M3 X2

11222   
M2.5x18 X16

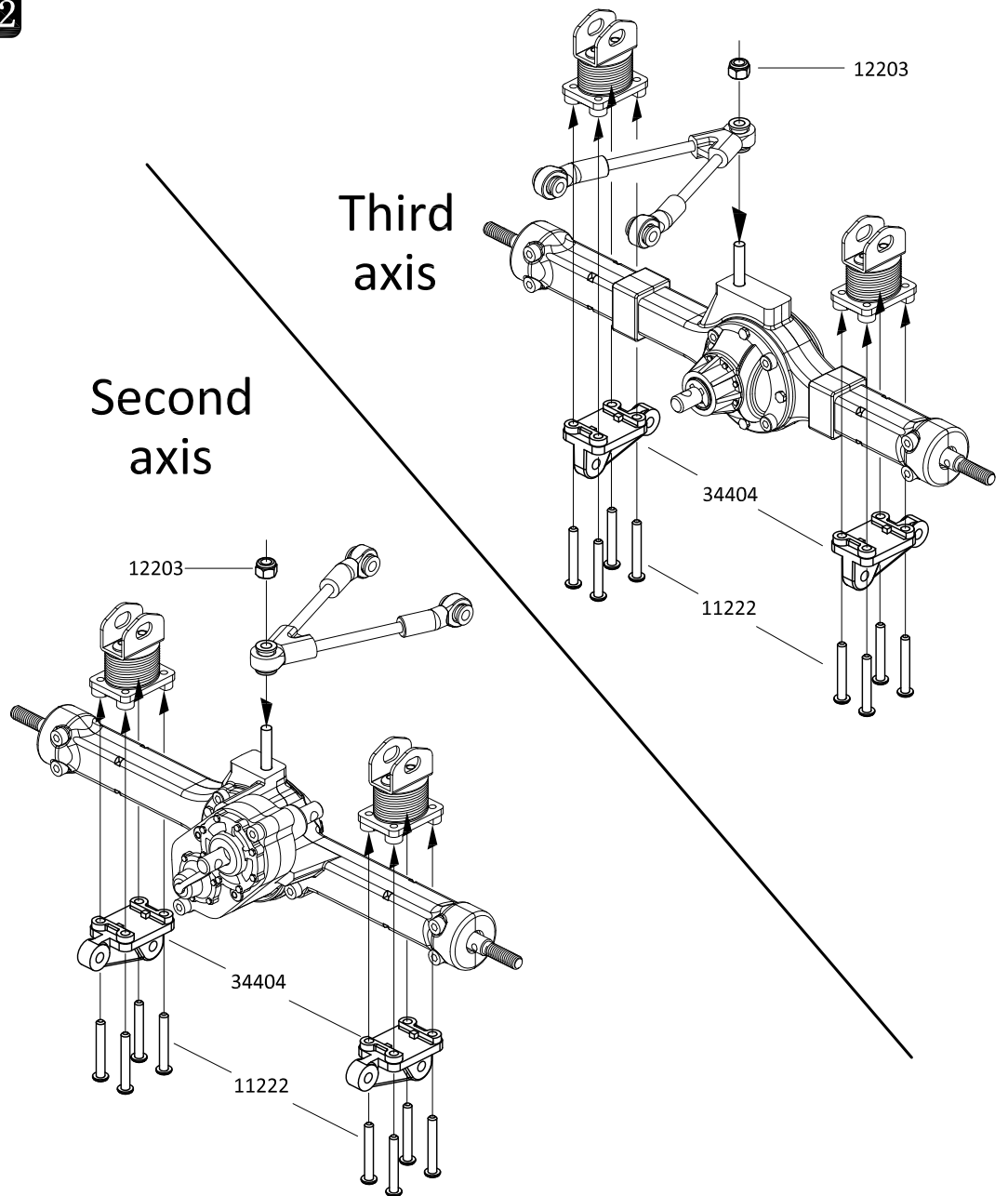

23

12203   
M3 X4

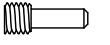
11409   
M4x11 X2

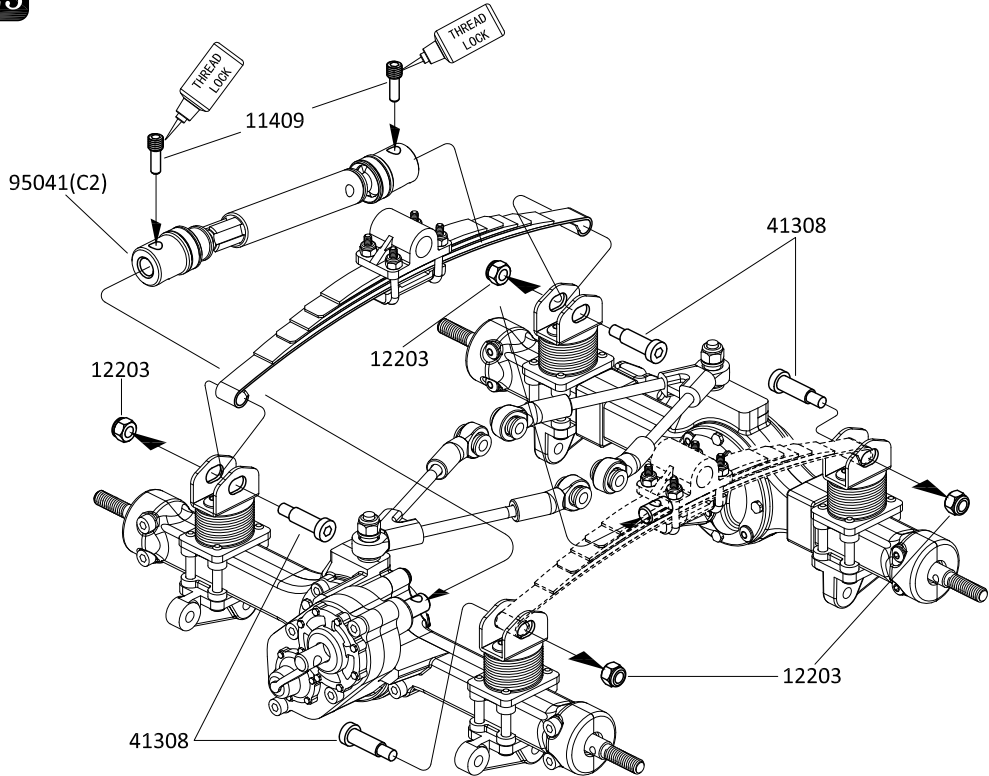

24

12203   
M3 X4

11211   
M3x18 X4

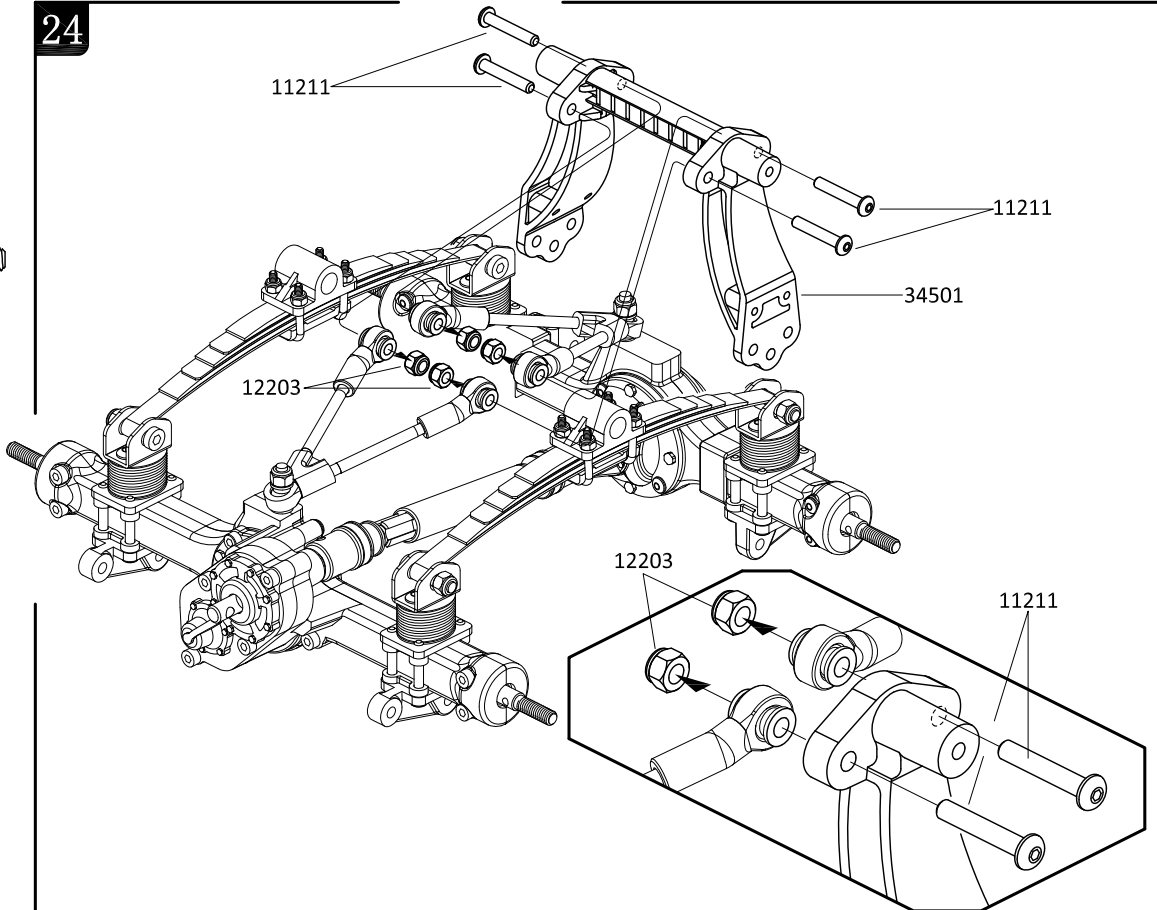

25

12203   
M3 X8

11211   
M3x18 X8

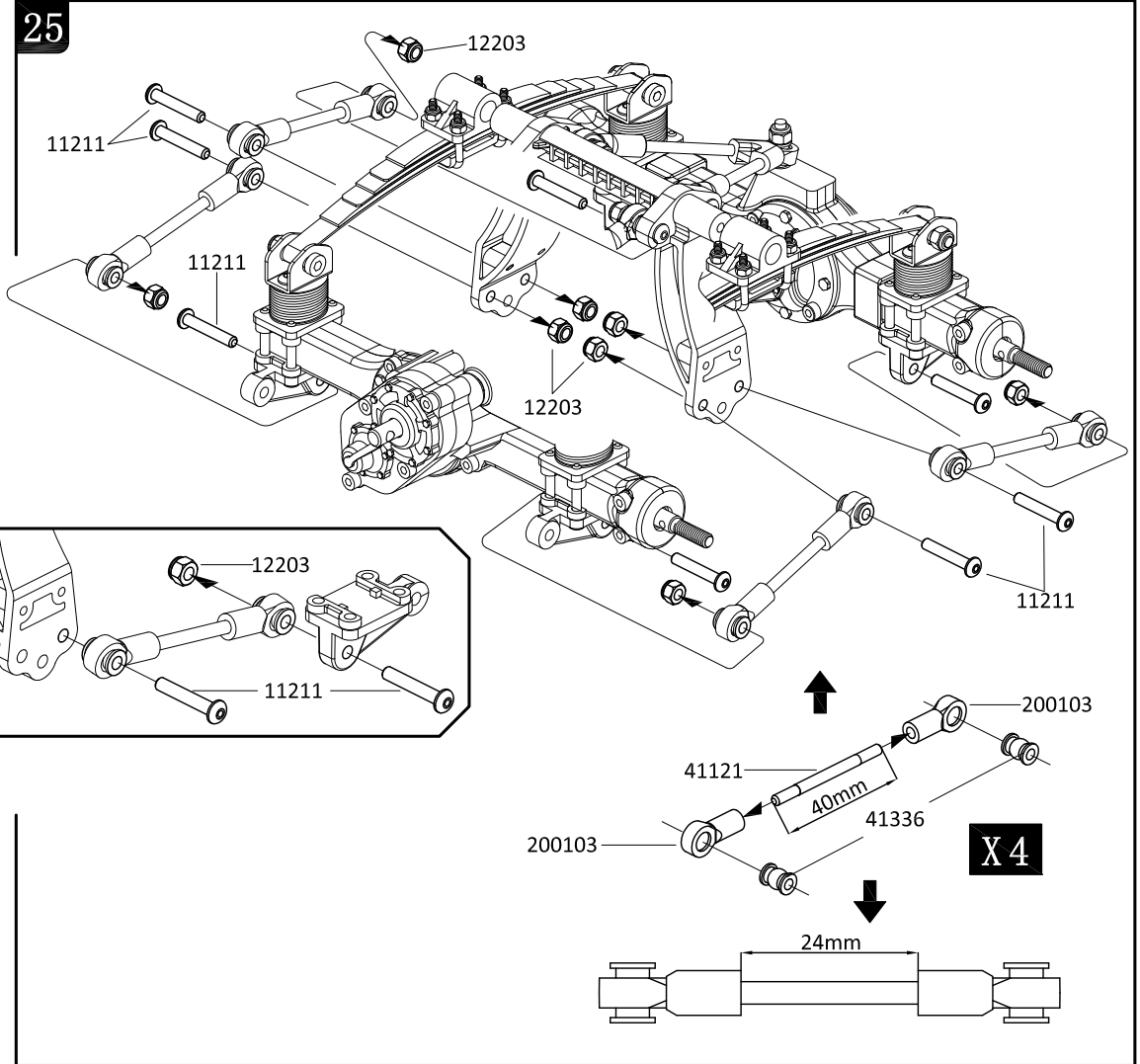
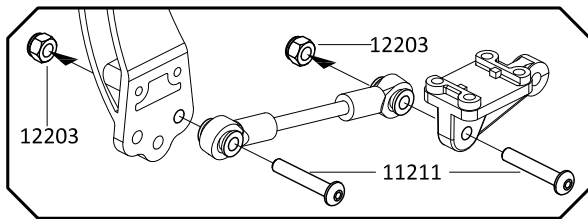

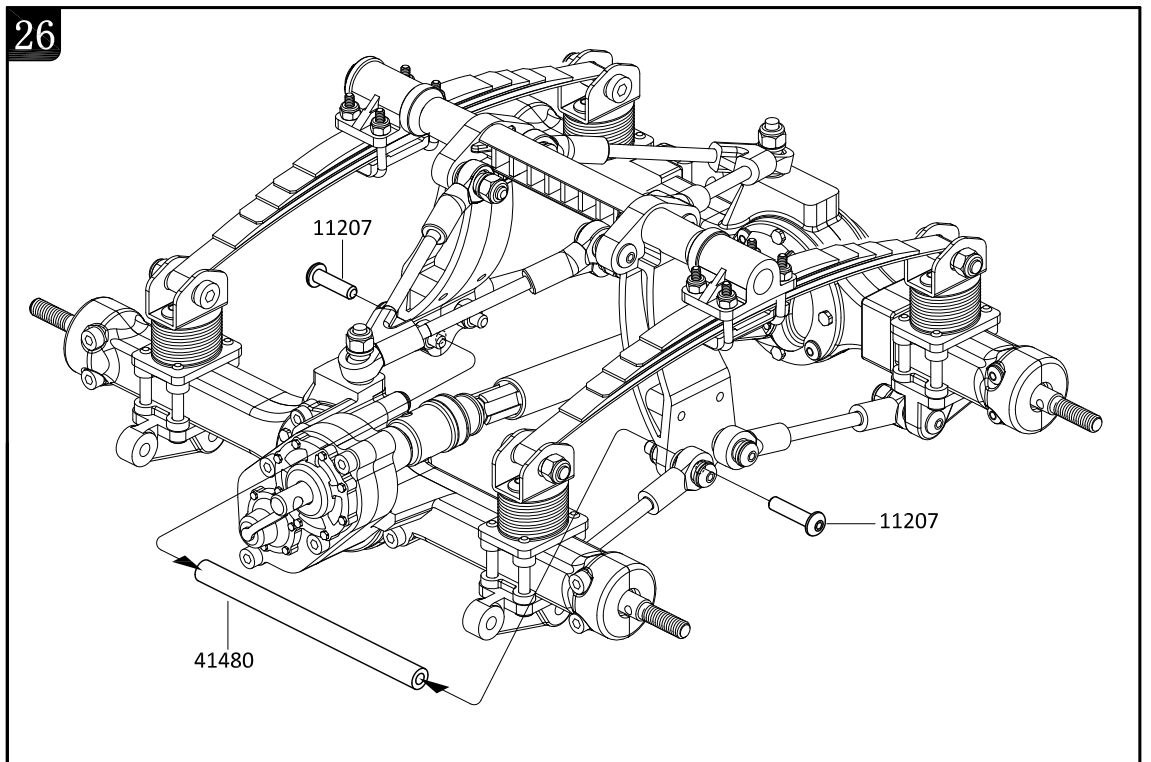

26

11207   
M3x10 X2



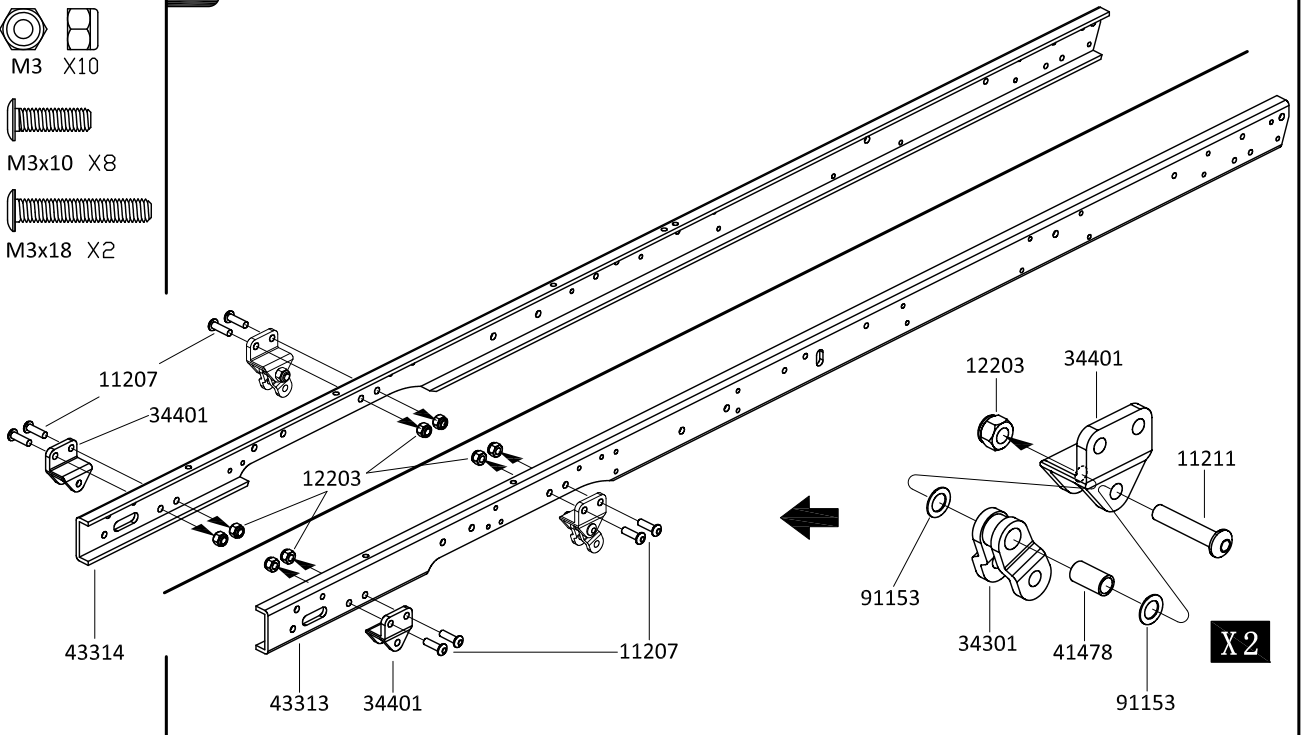

27

- 12203  M3 X10
- 11207  M3x10 X8
- 11211  M3x18 X2





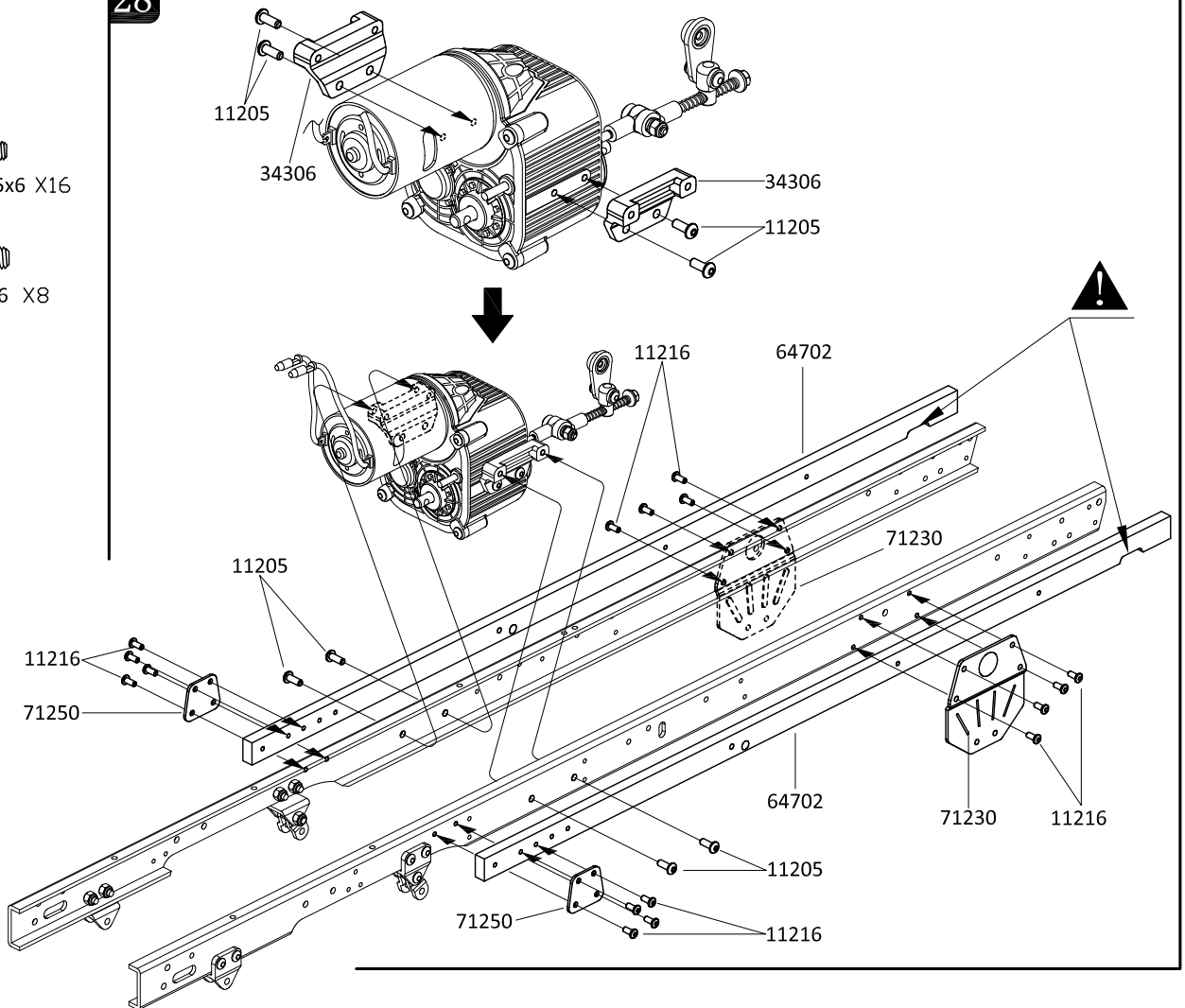

28

- 11216  M2.5x6 X16
- 11205  M3x6 X8



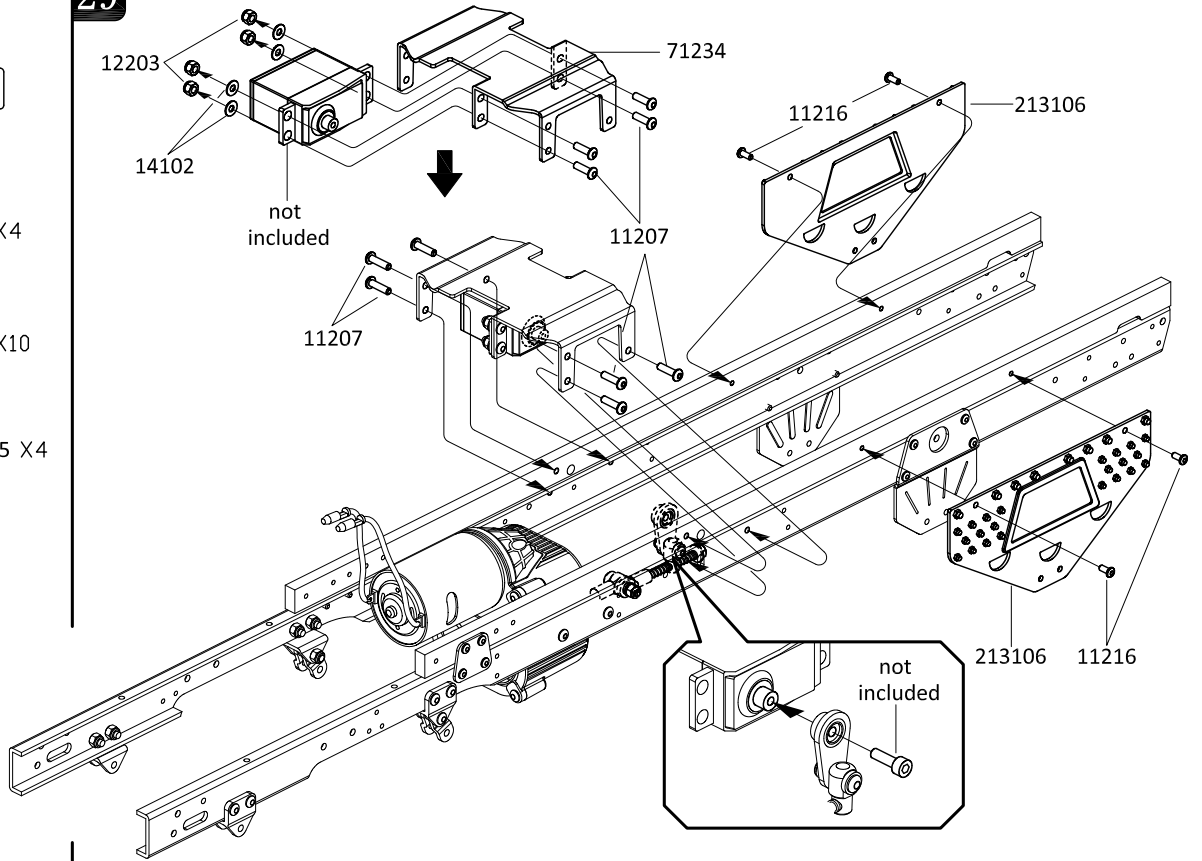

29

- 12203  M3 X4
- 11216  M2.5x6 X4
- 11207  M3x10 X10
- 14102  ø3xø7x0.5 X4



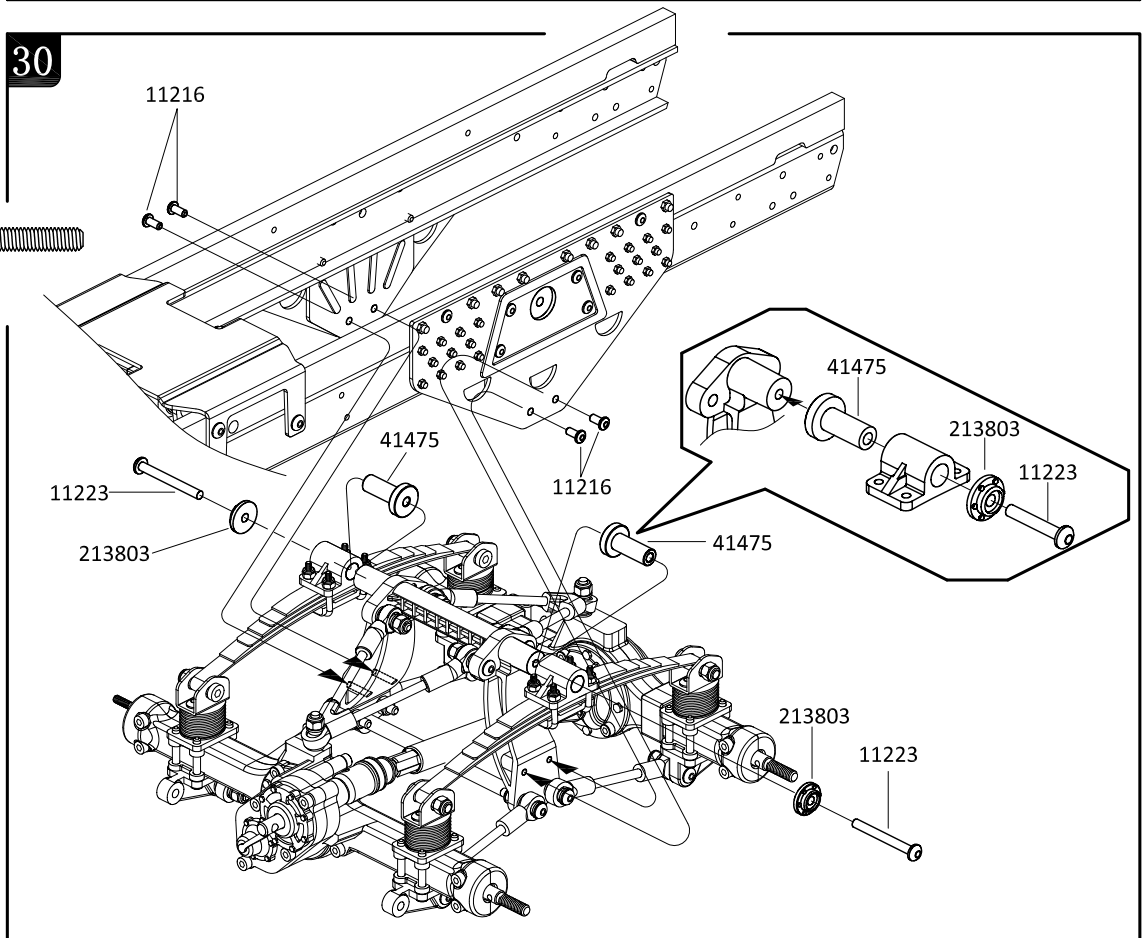

30

- 11216  M2.5x6 X4
- 11223  M3x30 X2



31

11216  M2.5x6 X14

12001  M2x6 X4

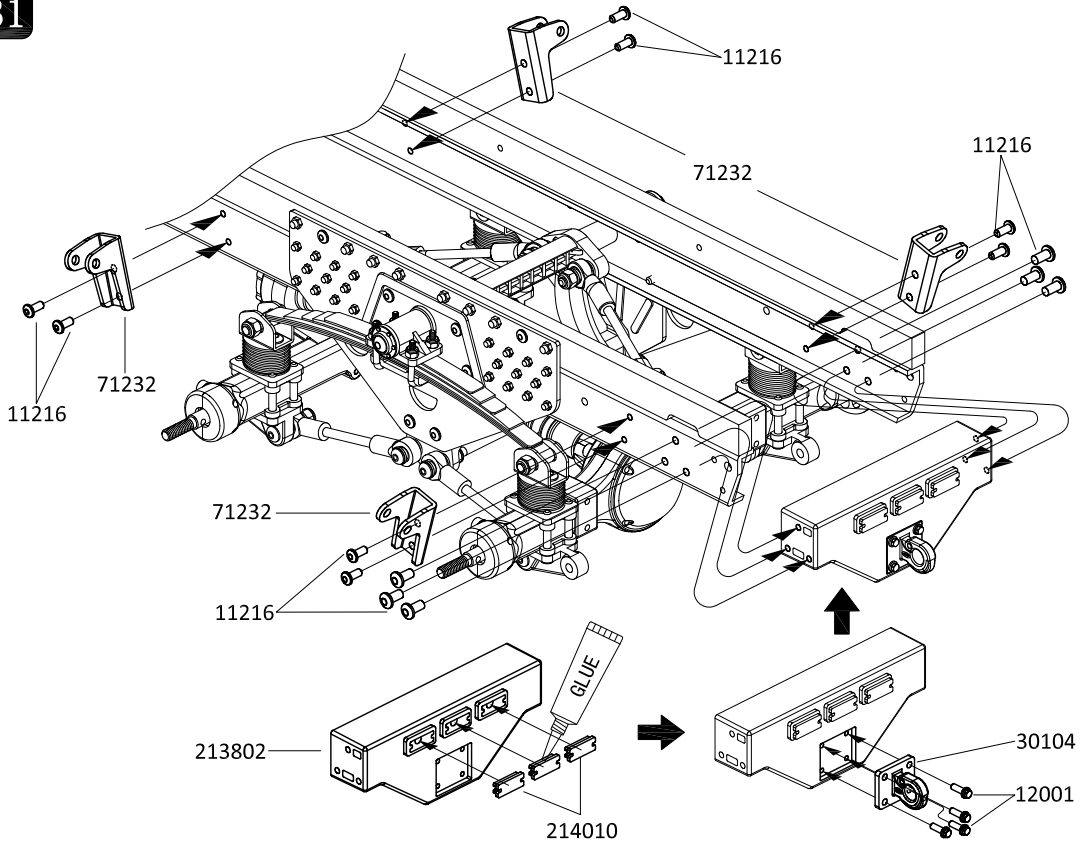
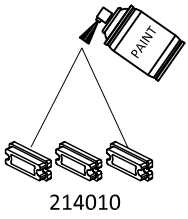



32

12203  M3 X8

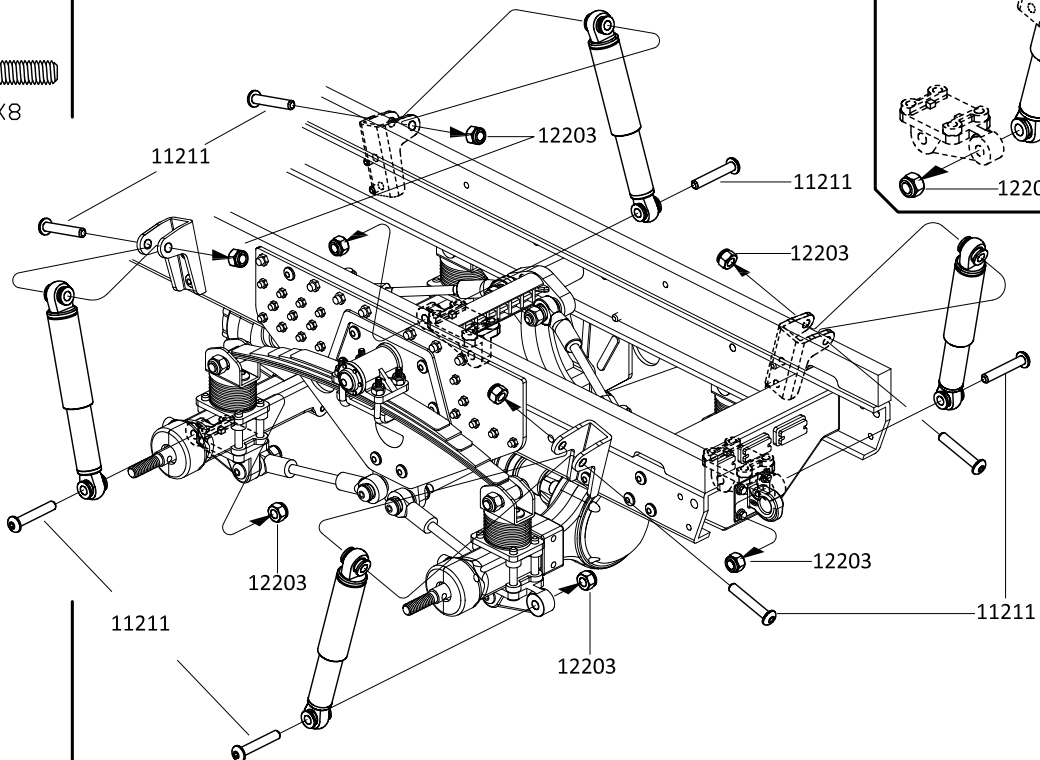
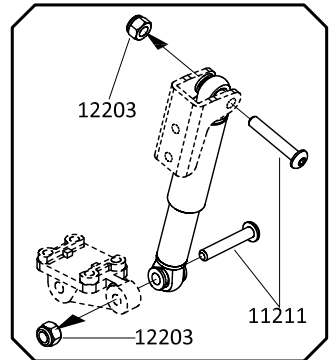
11211  M3x18 X8



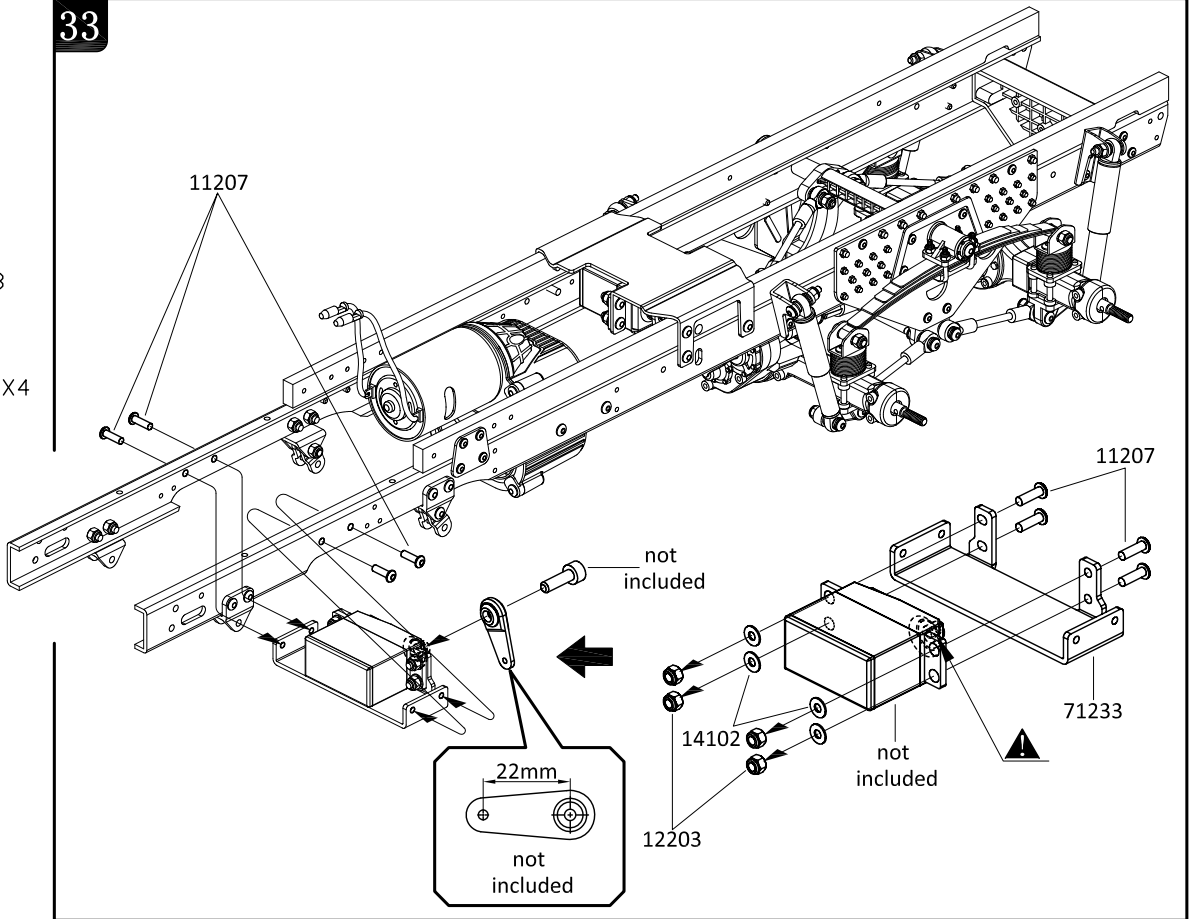

33

- 12203  M3 X4
- 11207  M3x10 X8
- 14102   $\phi 3 \times \phi 7 \times 0.5$  X4



34

- 12203  M3 X5
- 11209  M3x14 X1
- 11211  M3x18 X4

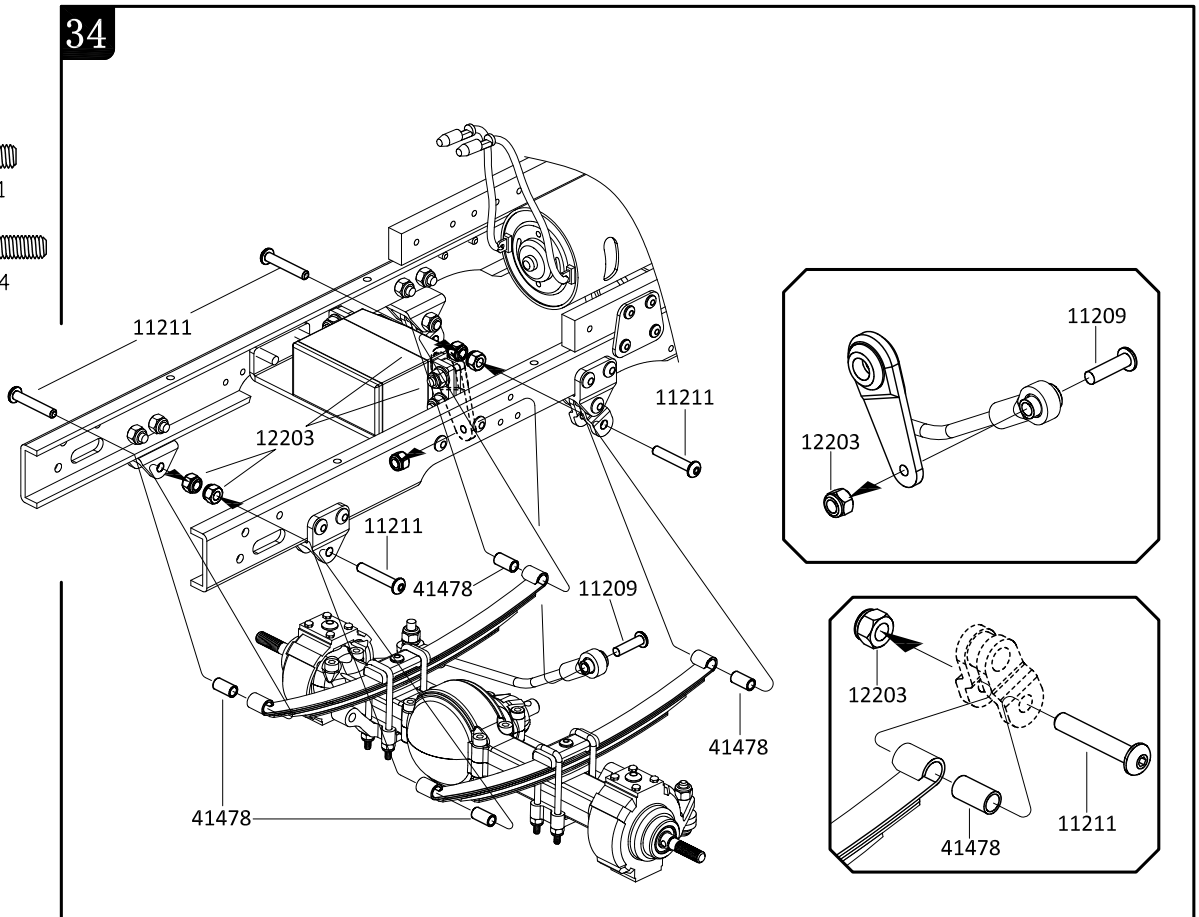

35

11216   
M2.5x6 X6

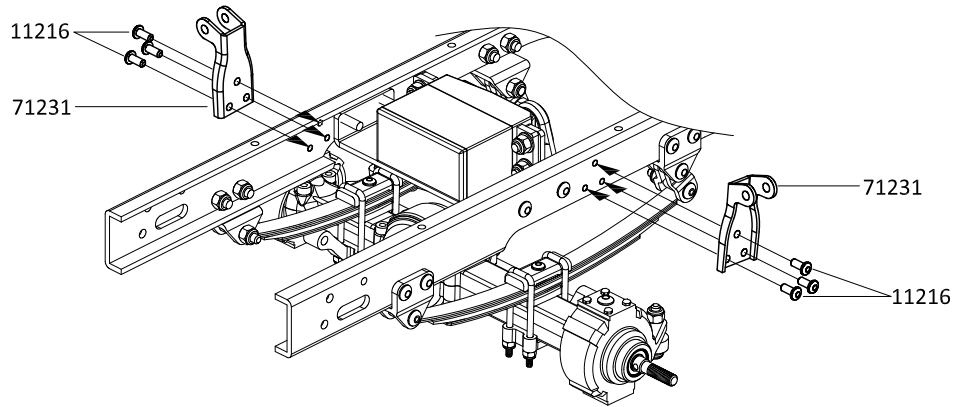

36

12203   
M3 X4

11211   
M3x18 X2

11212   
M3x20 X2

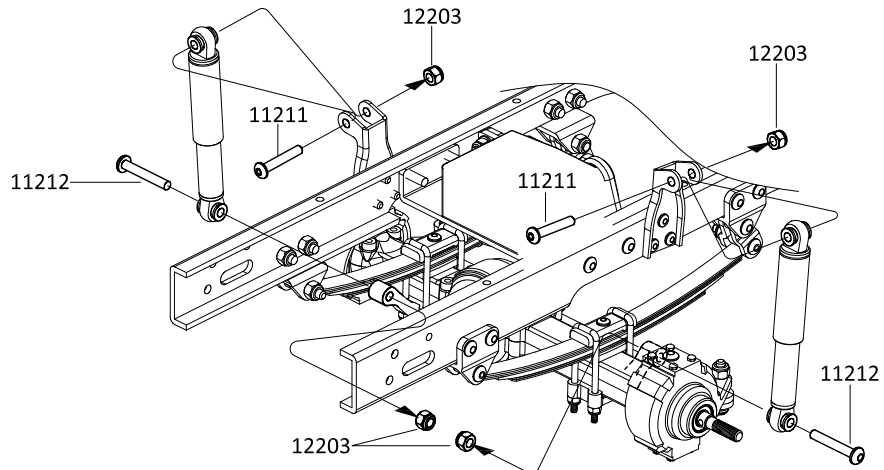

37

11216   
M2.5x6 X4

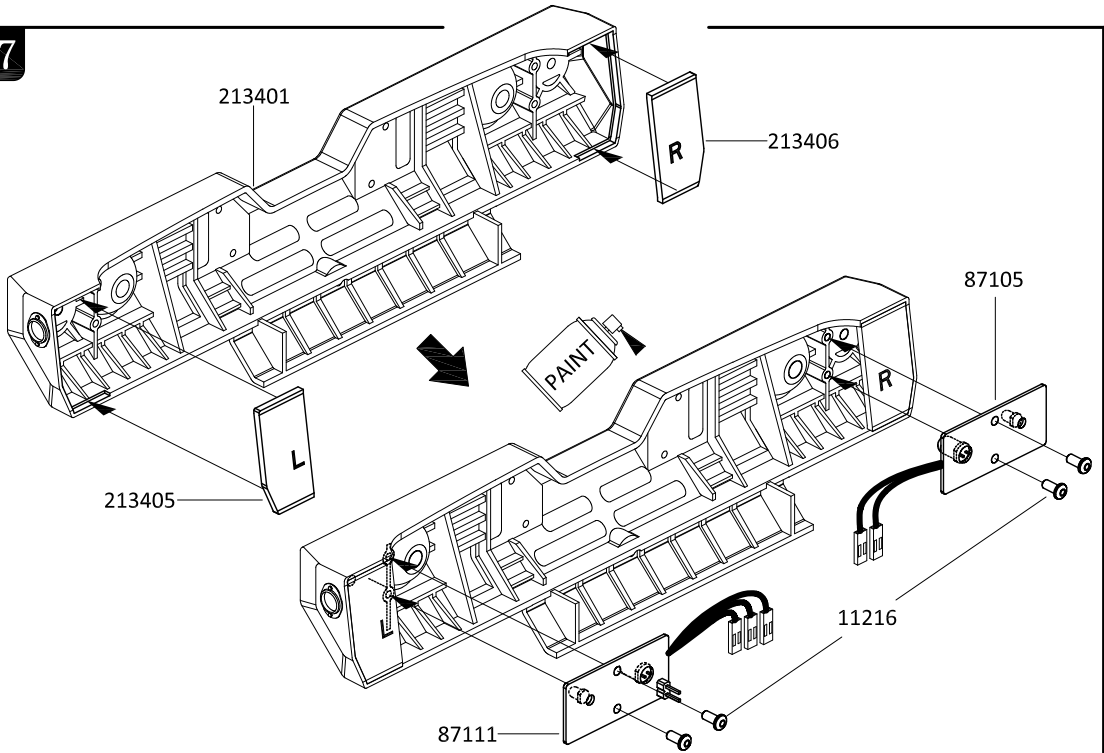
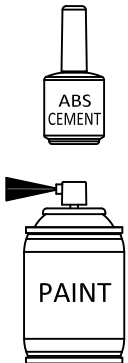

38

11205   
M3x6 X6

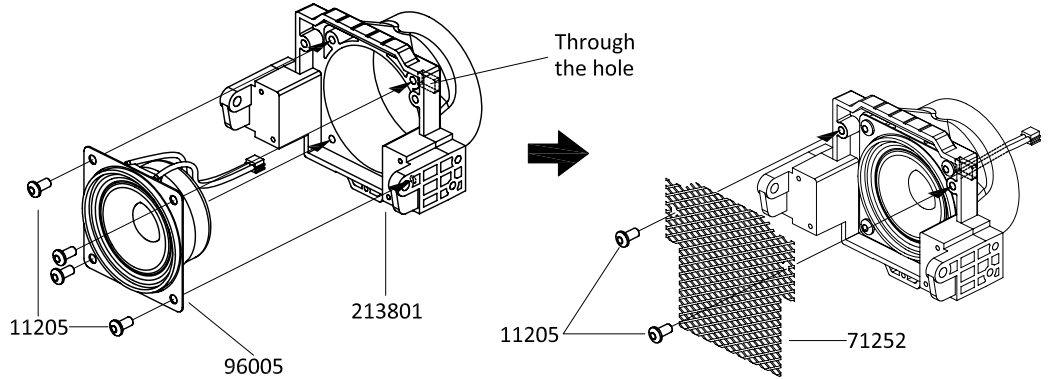

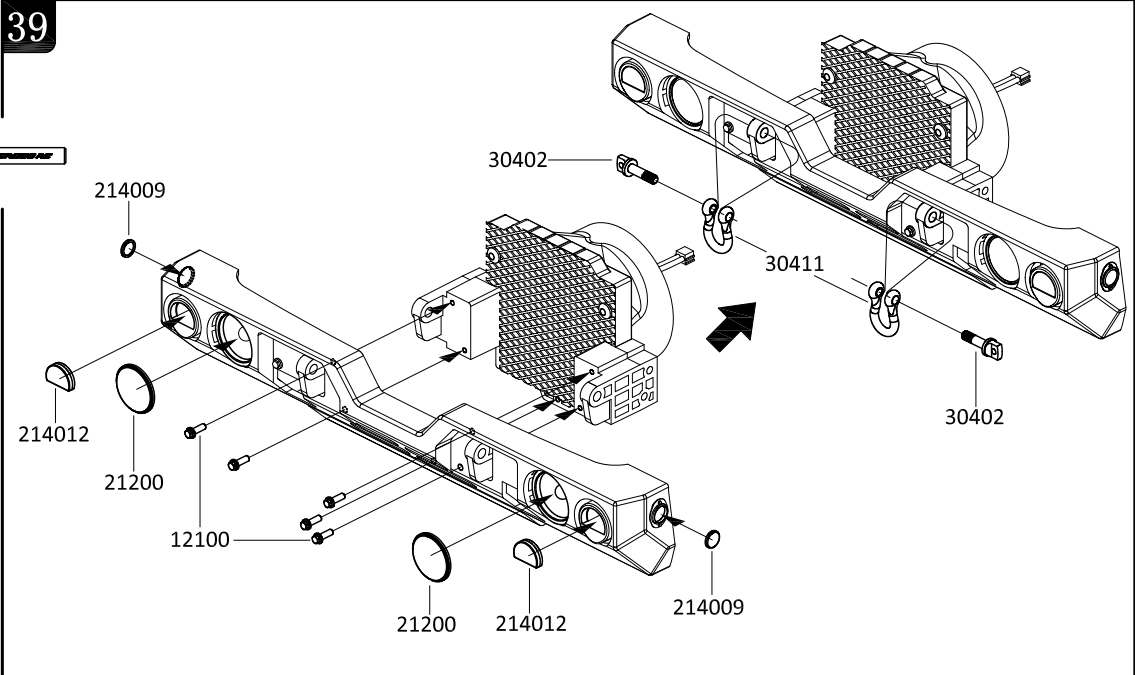
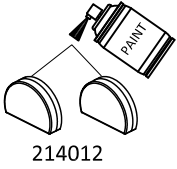

39

12001   
M2x6 X5



40

11207   
M3x10 X2

11409   
M4x11 X4

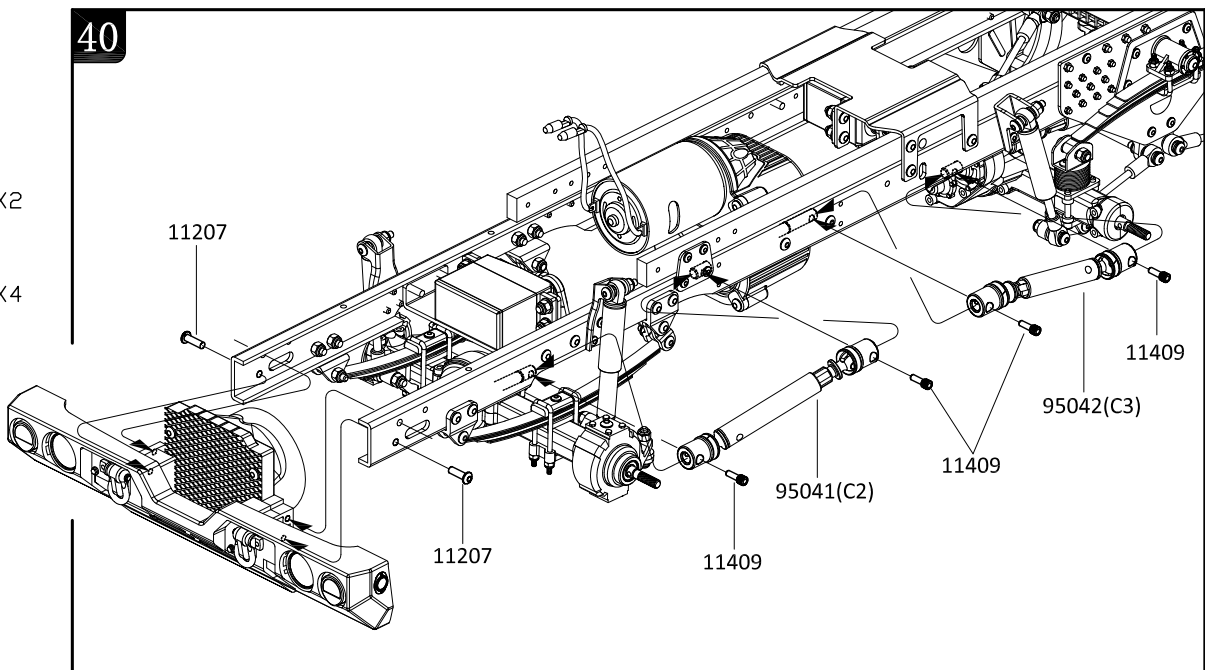

41

11202  M2x6 X1

11216  M2.5x6 X2

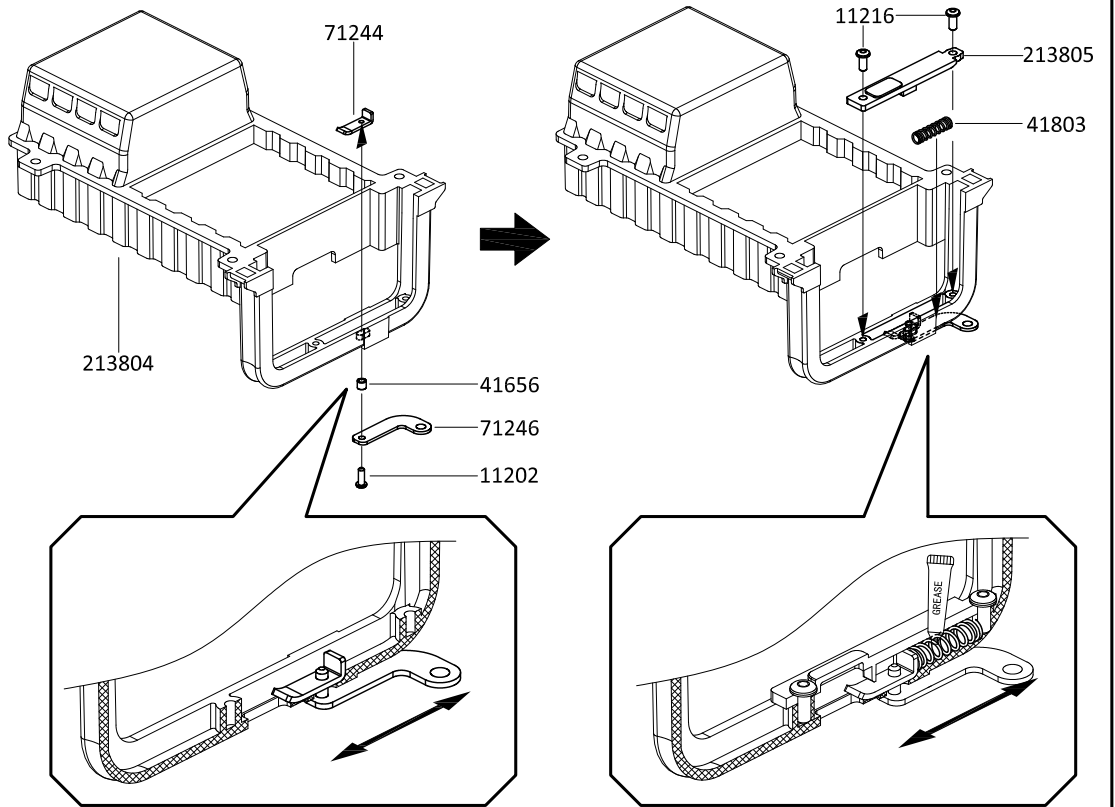

42

11205  M3x6 X4

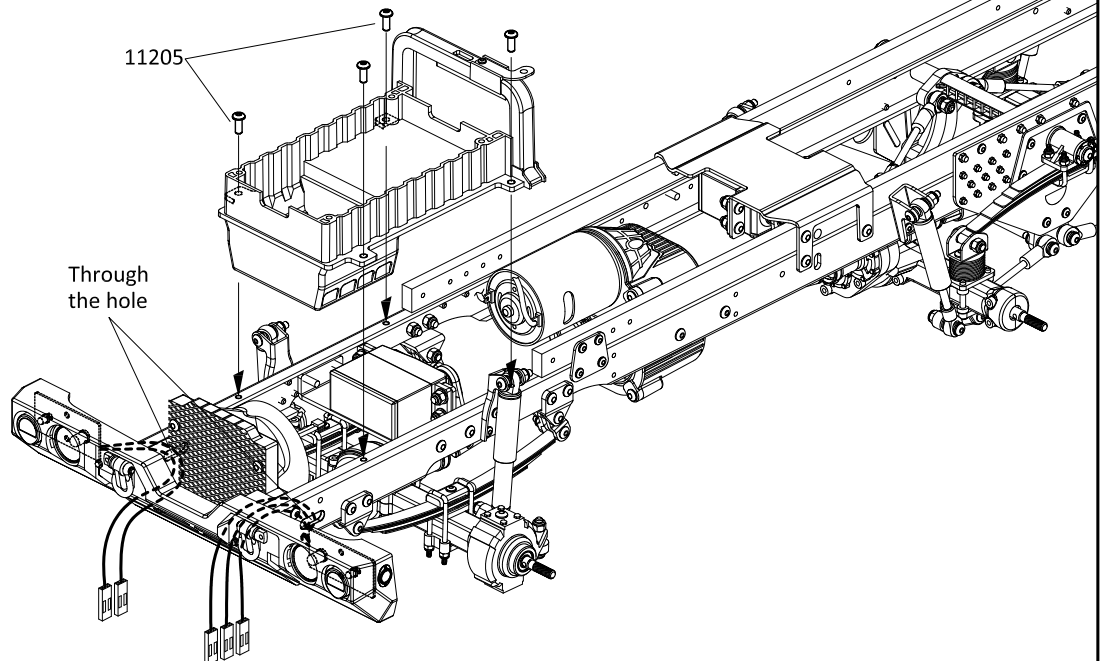

43

11202  M2x6 X12

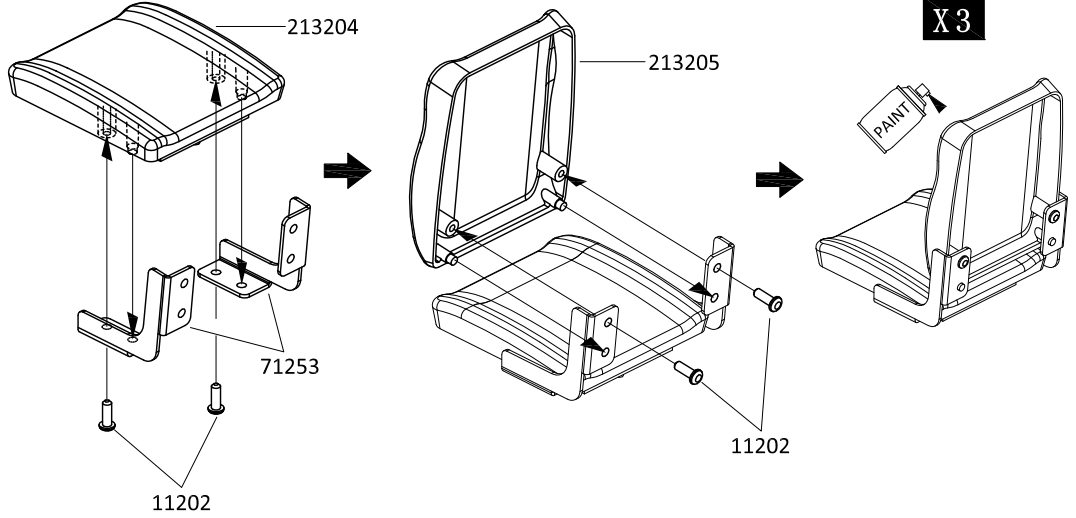

44

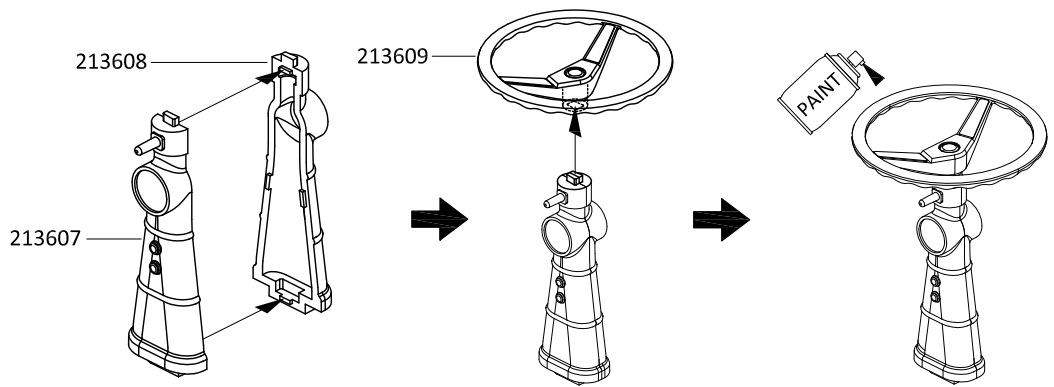
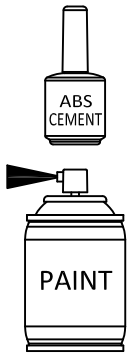

45

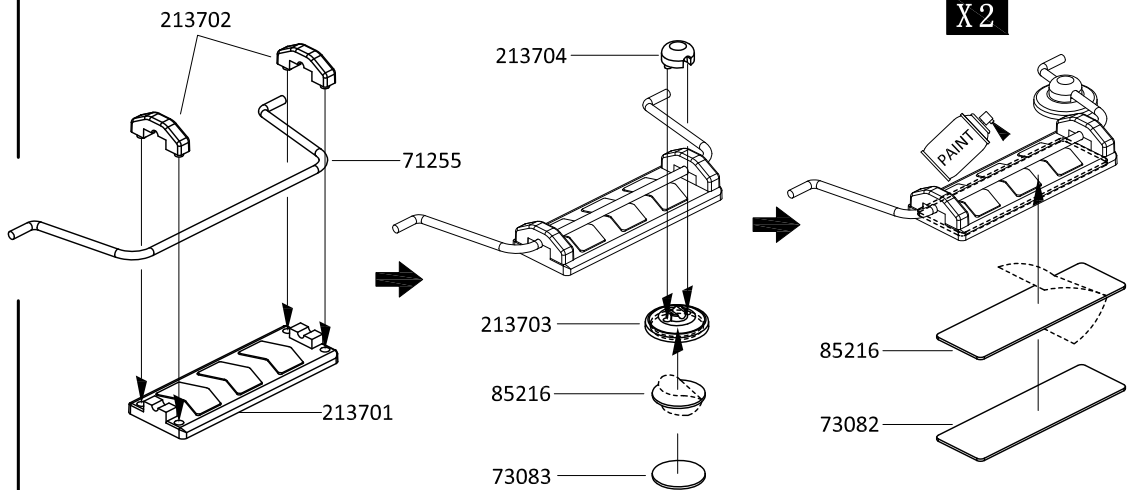
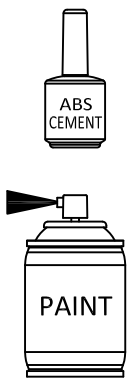

46

11802  ST1.4x4 X4

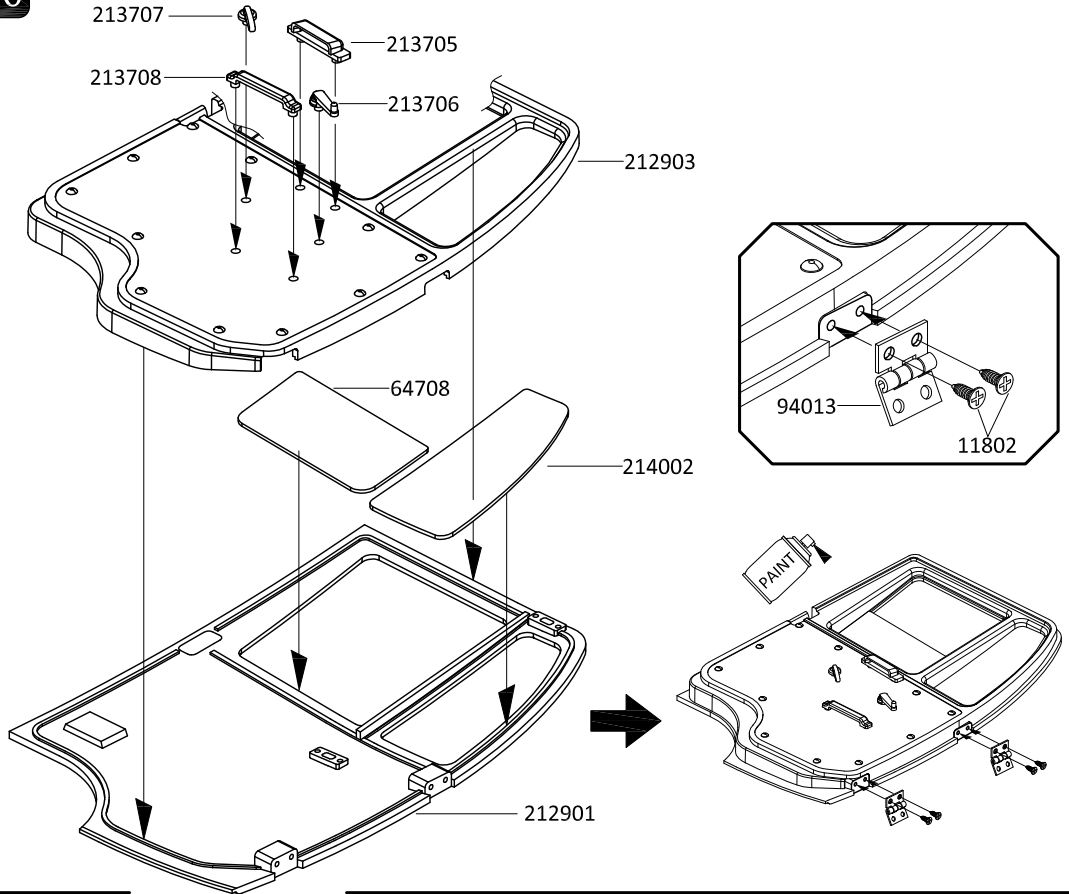

47

11802  ST1.4x4 X4

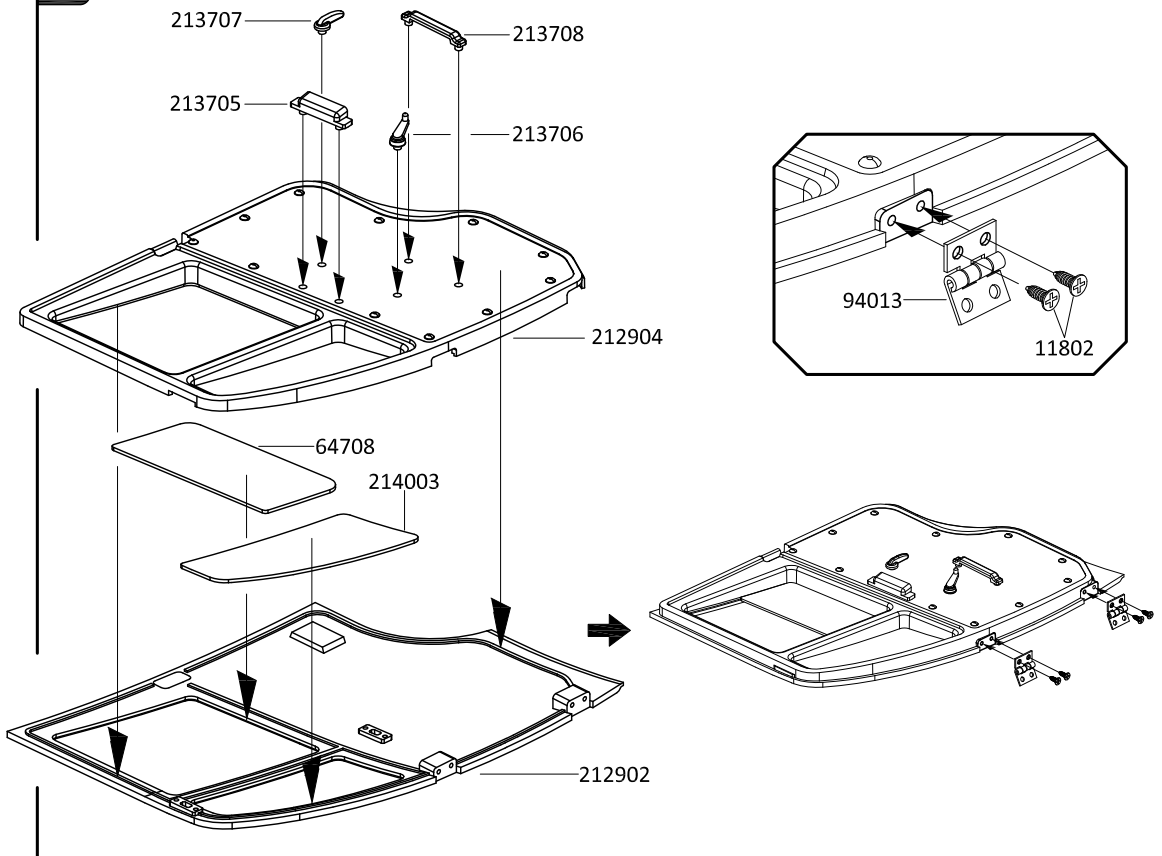



50

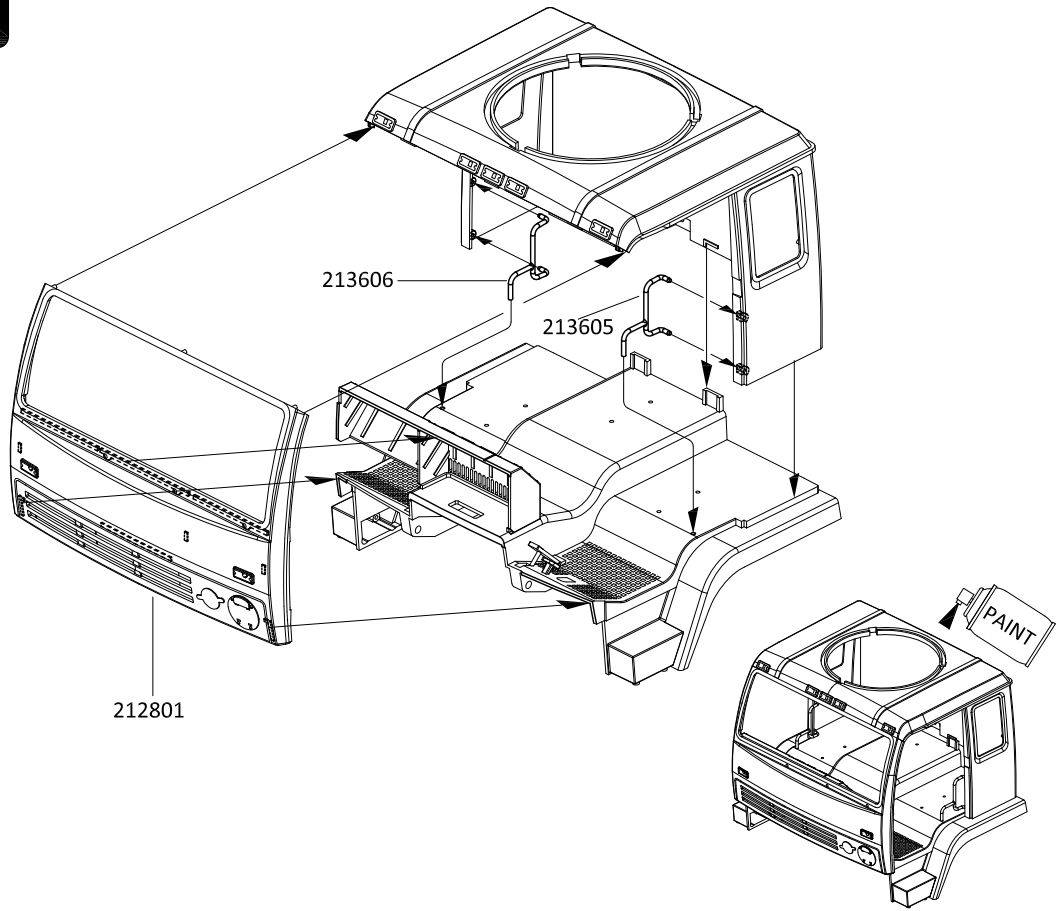
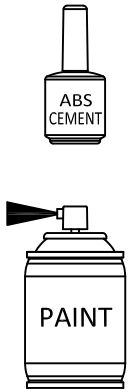

51

11218   
M2.5x4 X3

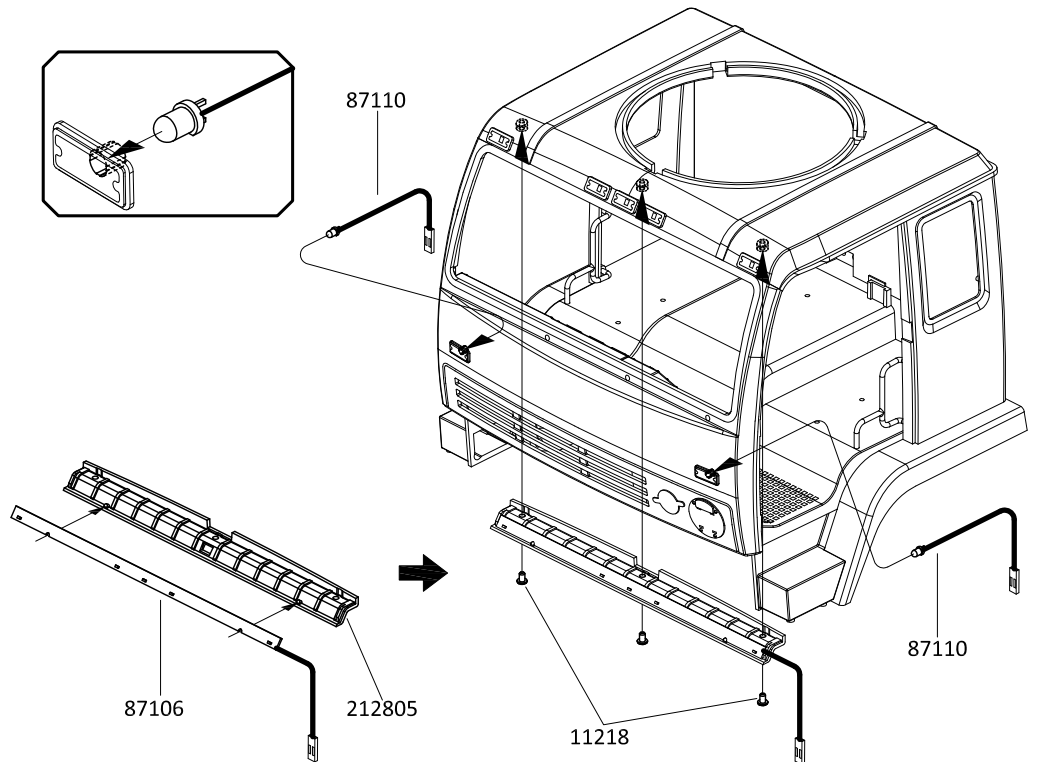

52

11218 M2.5x4 X2

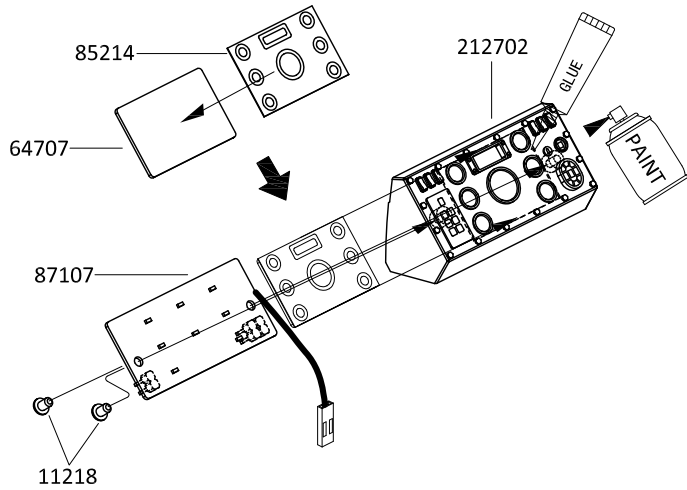

53

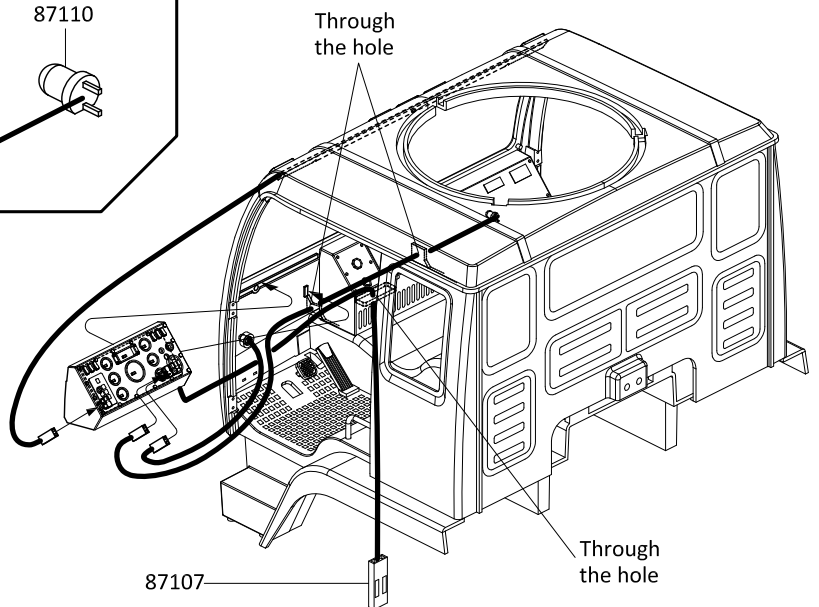
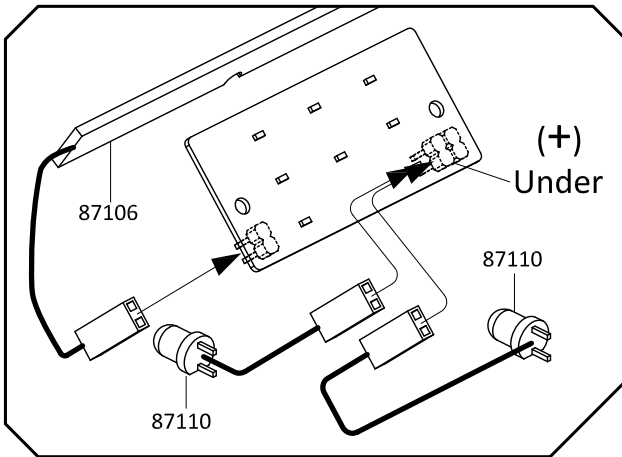
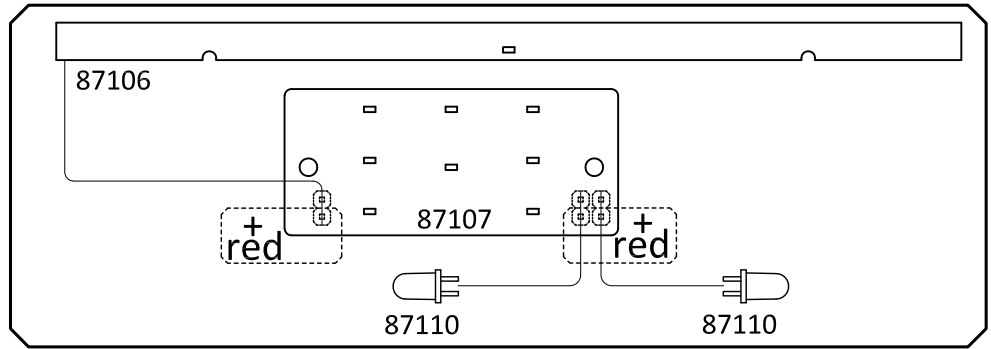

54

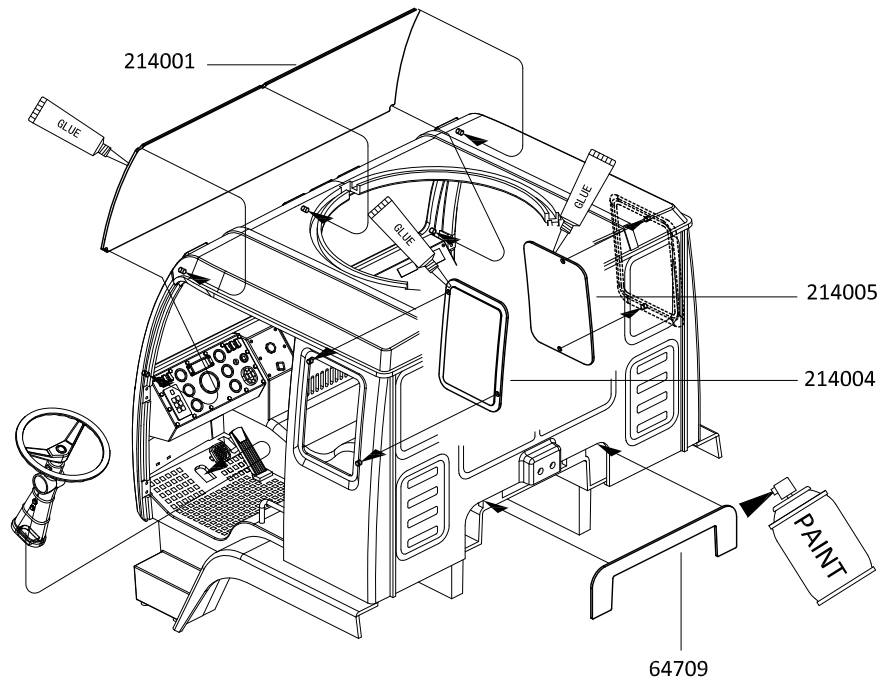

55

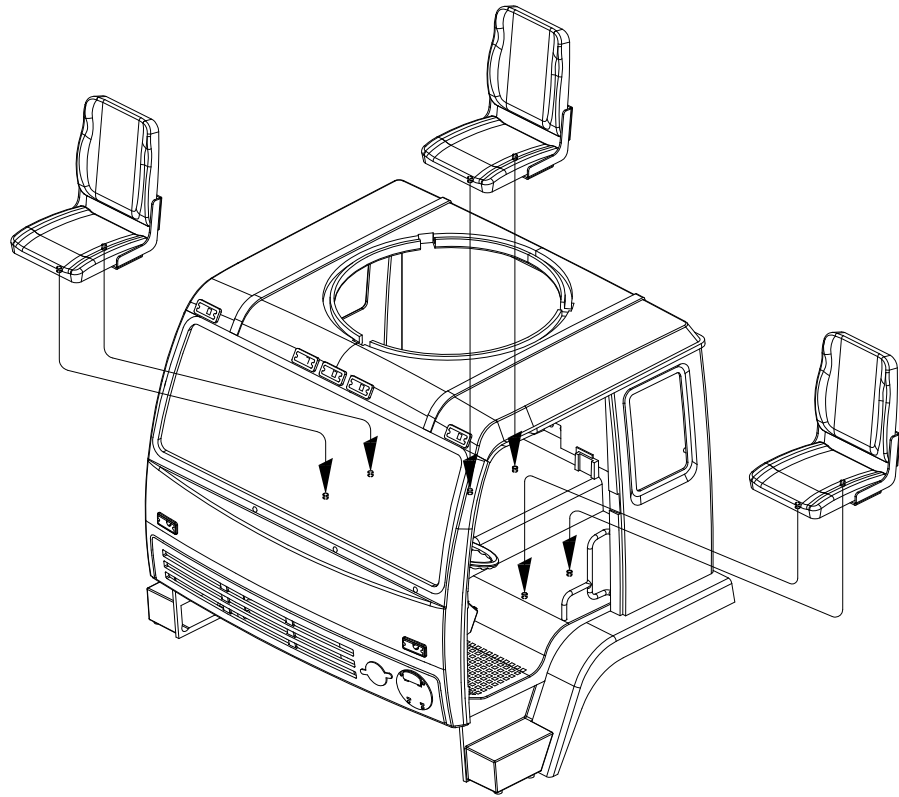

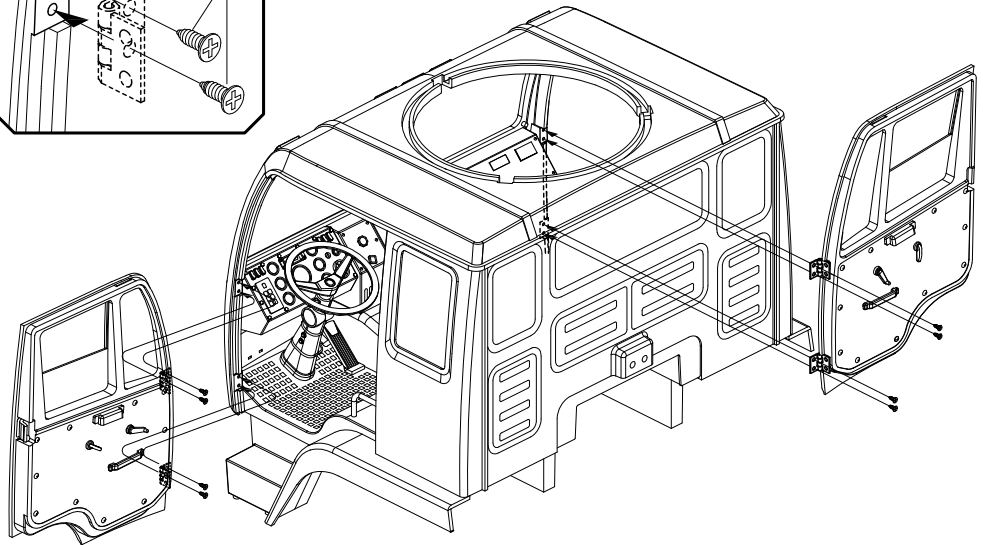
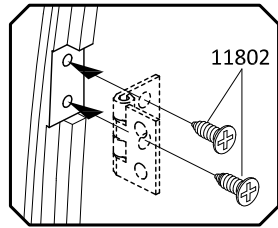

56

- 11802  ST1.4x4 X8



57

- 11127  M2.5x7 X4
- 11205  M3x6 X2
- 13001   $\varnothing 3 \times 7.2 \times 0.5$  X2

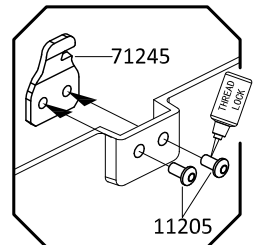
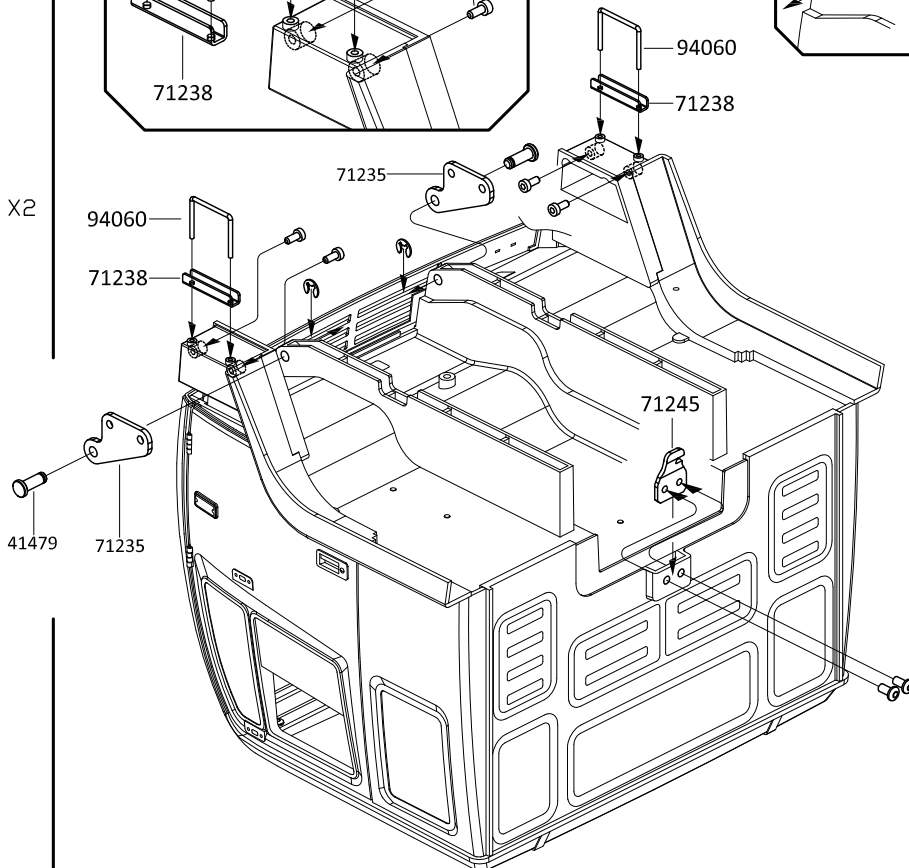
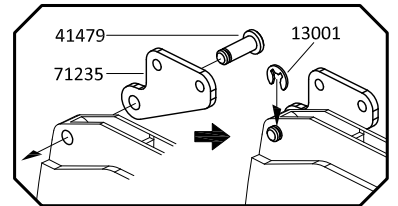
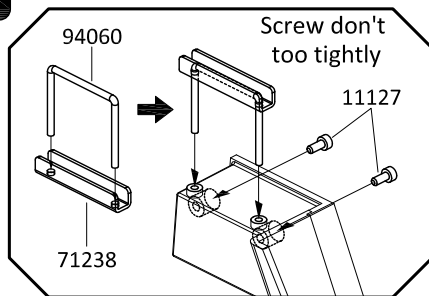

58

11802   
ST1.4x4 X8

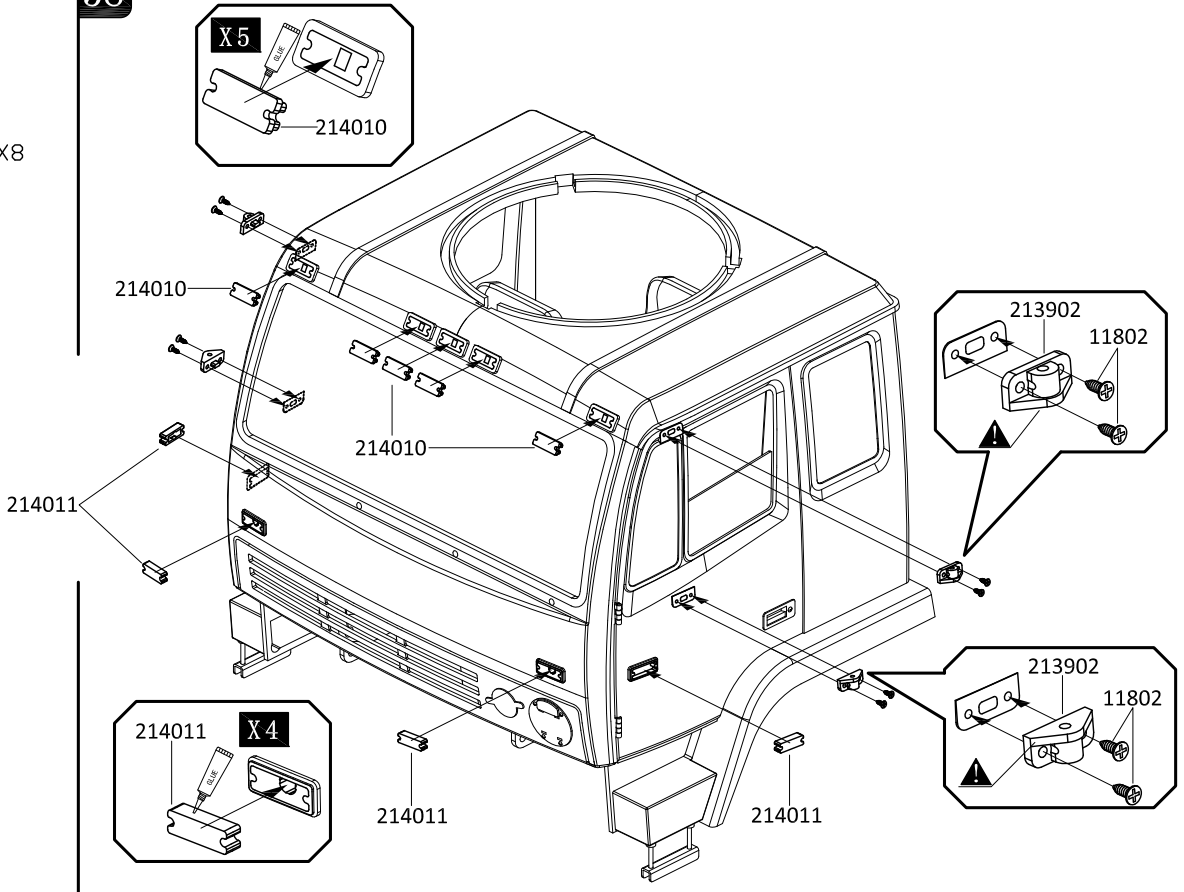

59

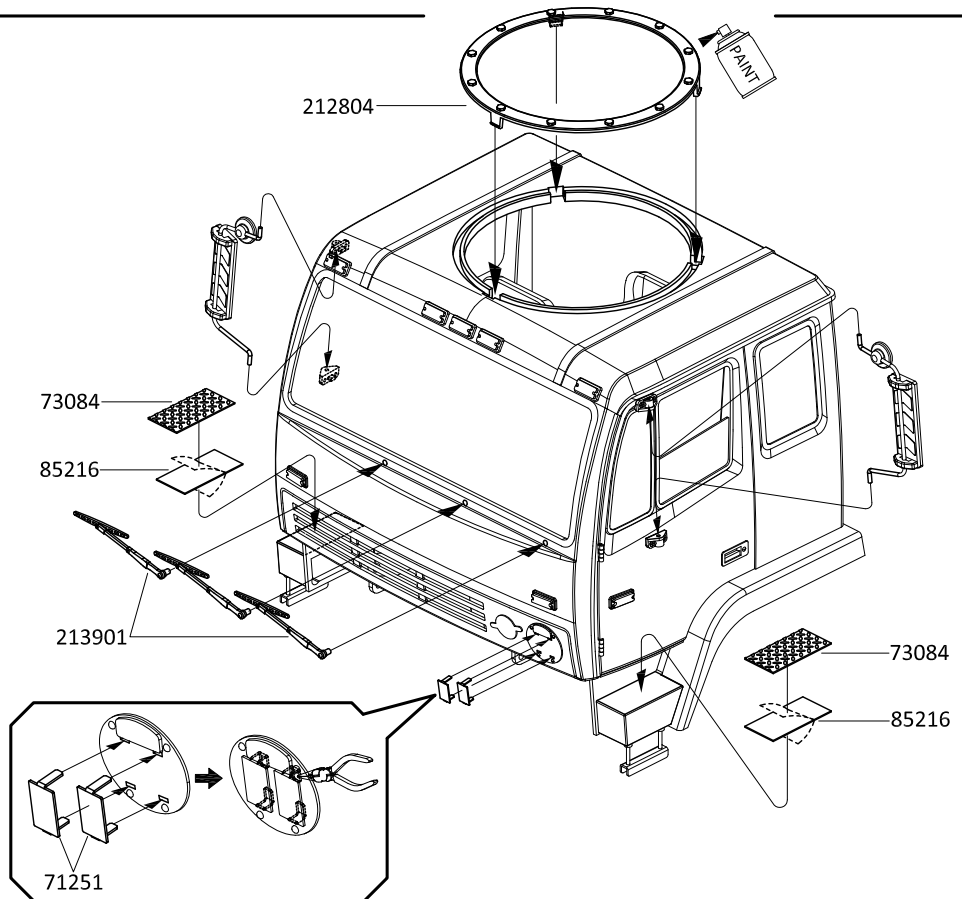

60

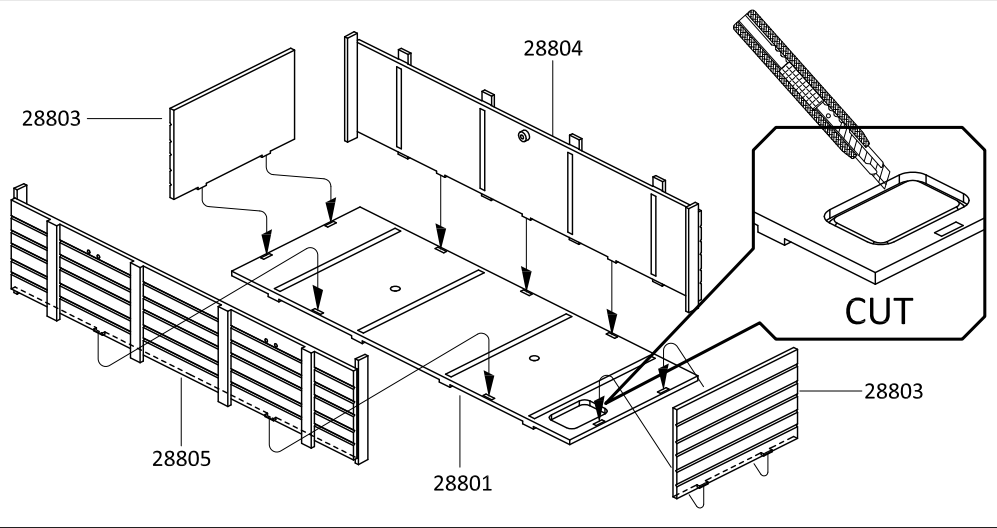

61

11802   
ST1.4x4 X8

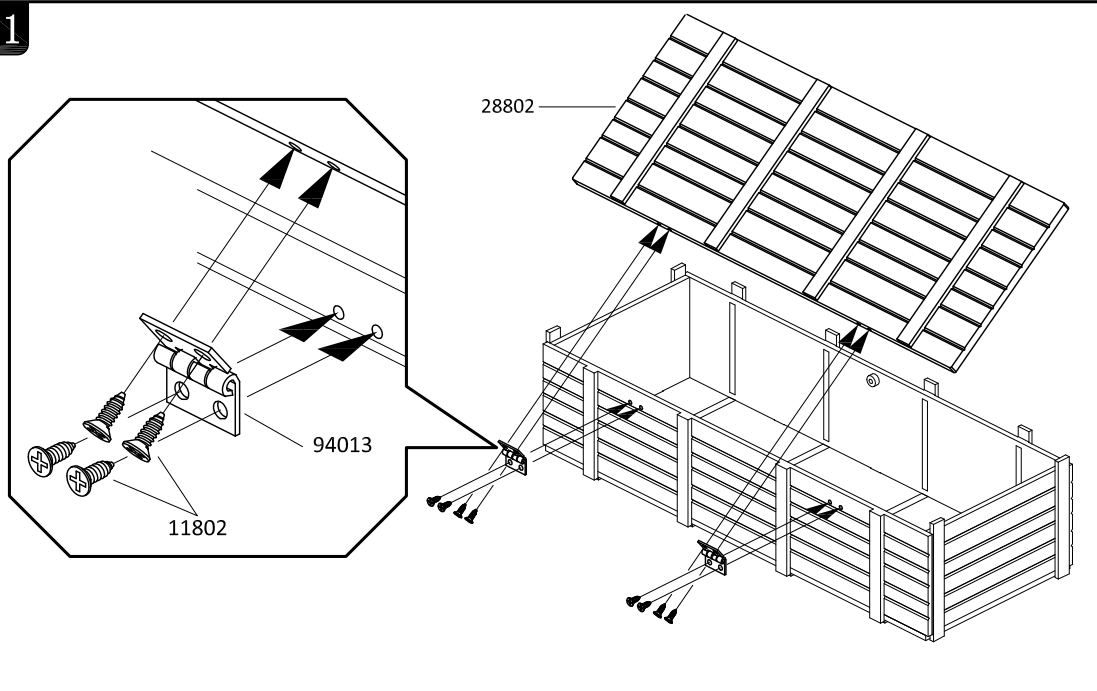

62

11704   
M1.6x6 X2

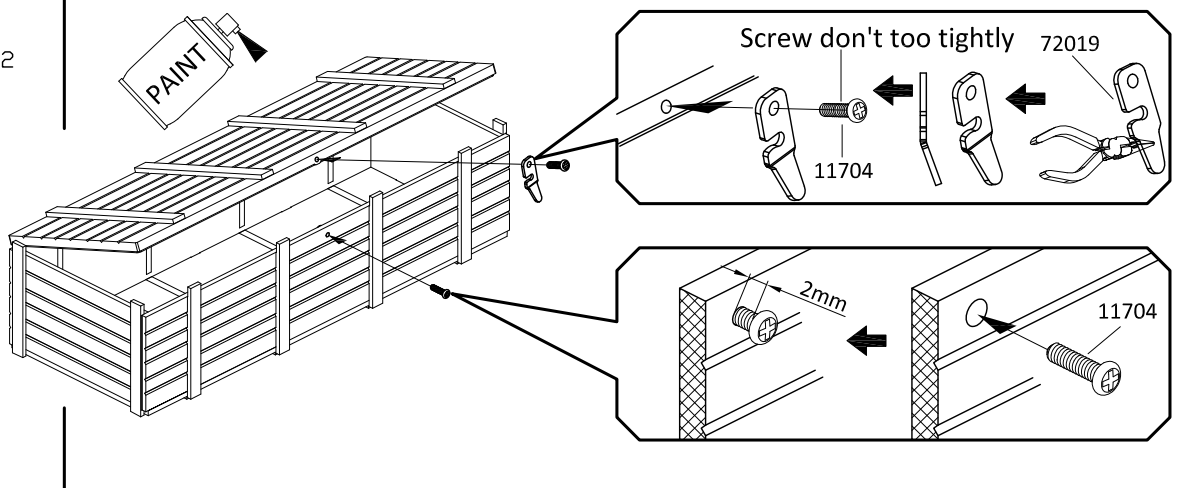



64

11202   
M2x6 X8

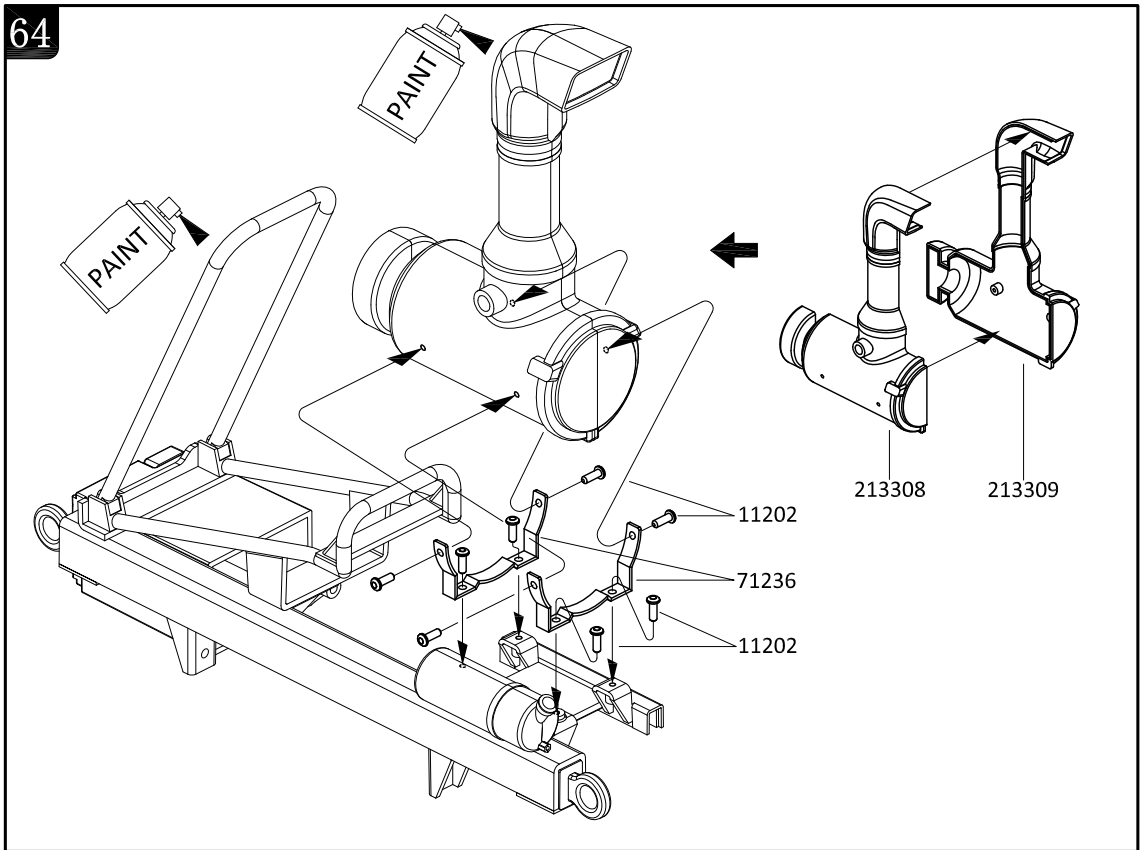
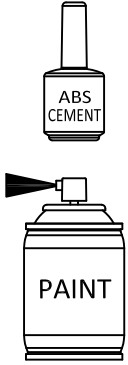

65

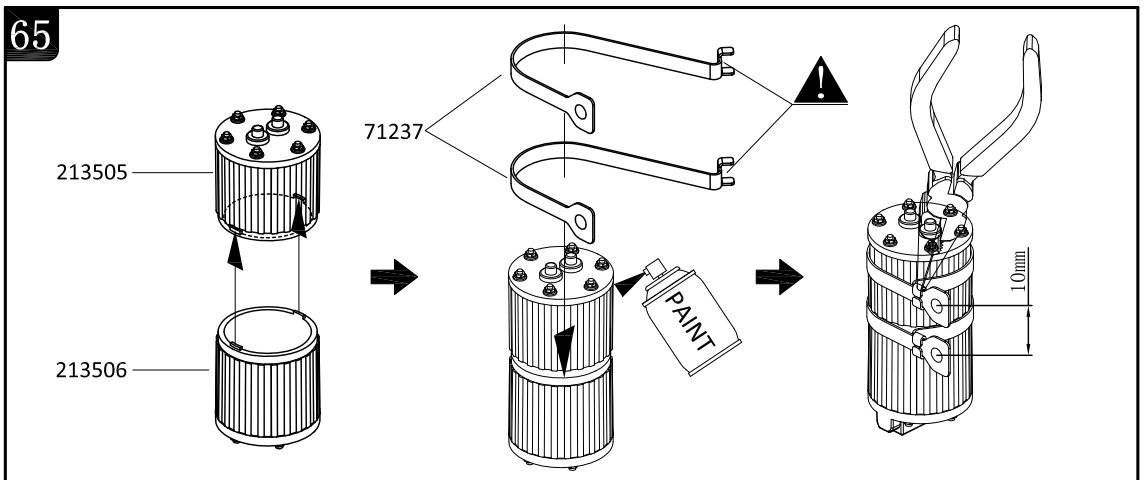
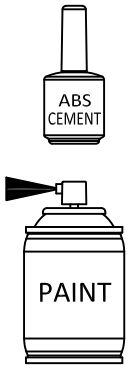

66

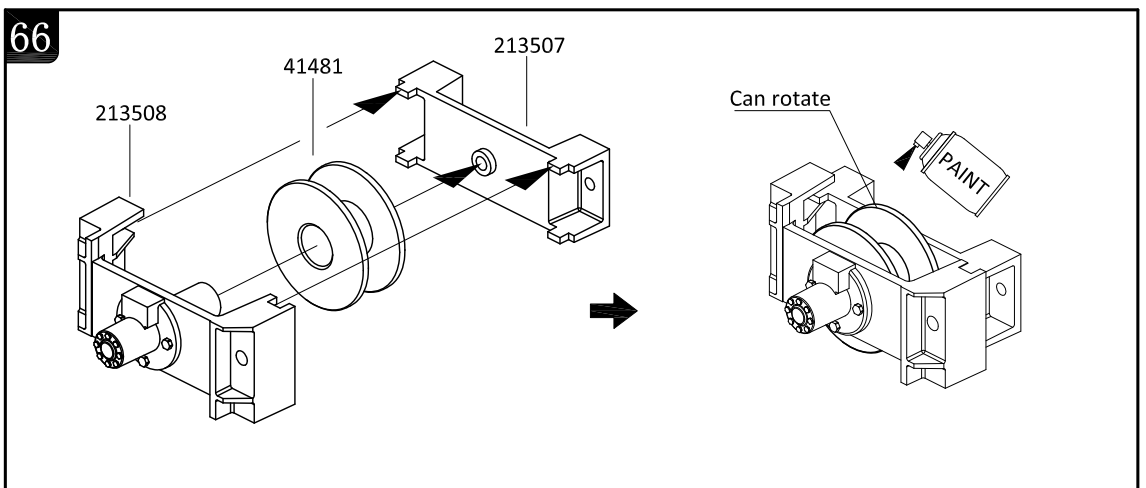
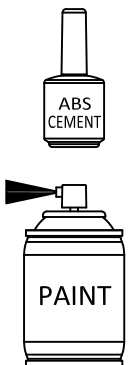

67

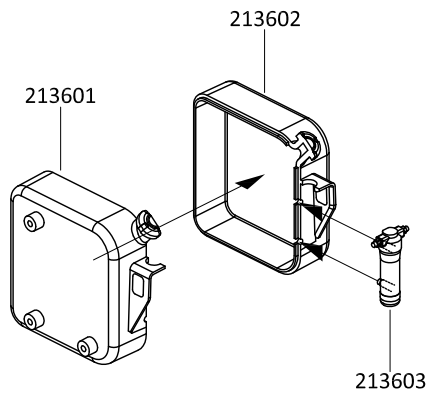

68

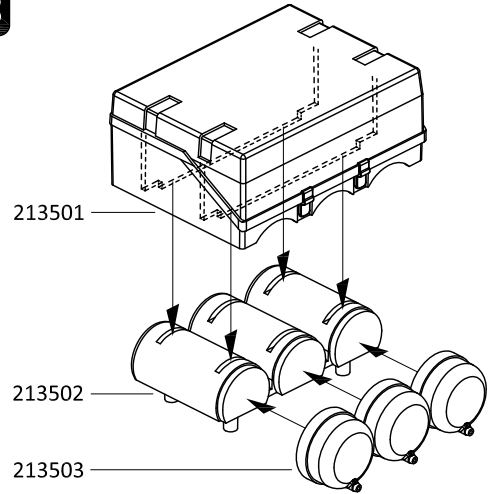

69

12206  M2 X2

11202  M2x6 X9

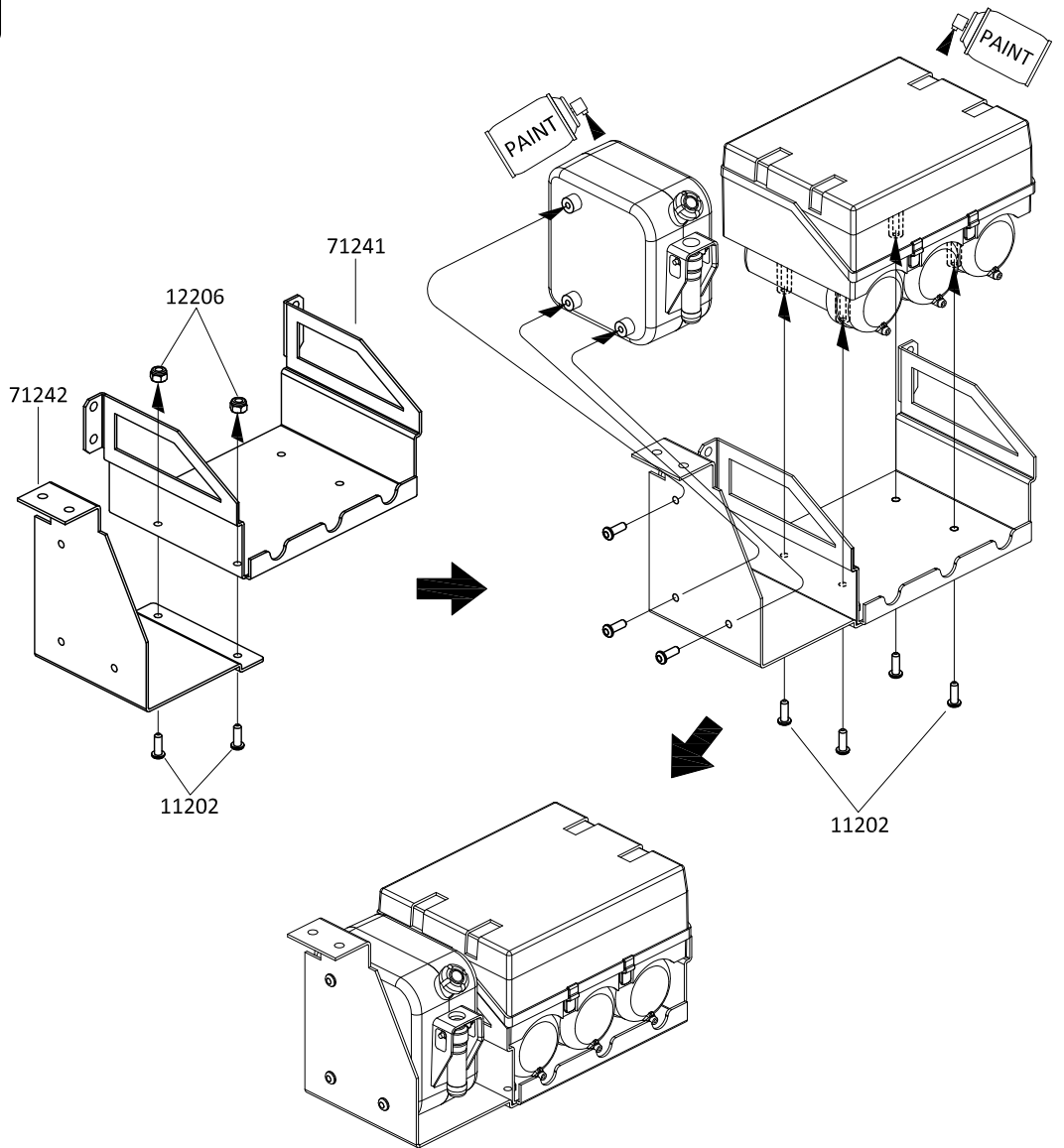

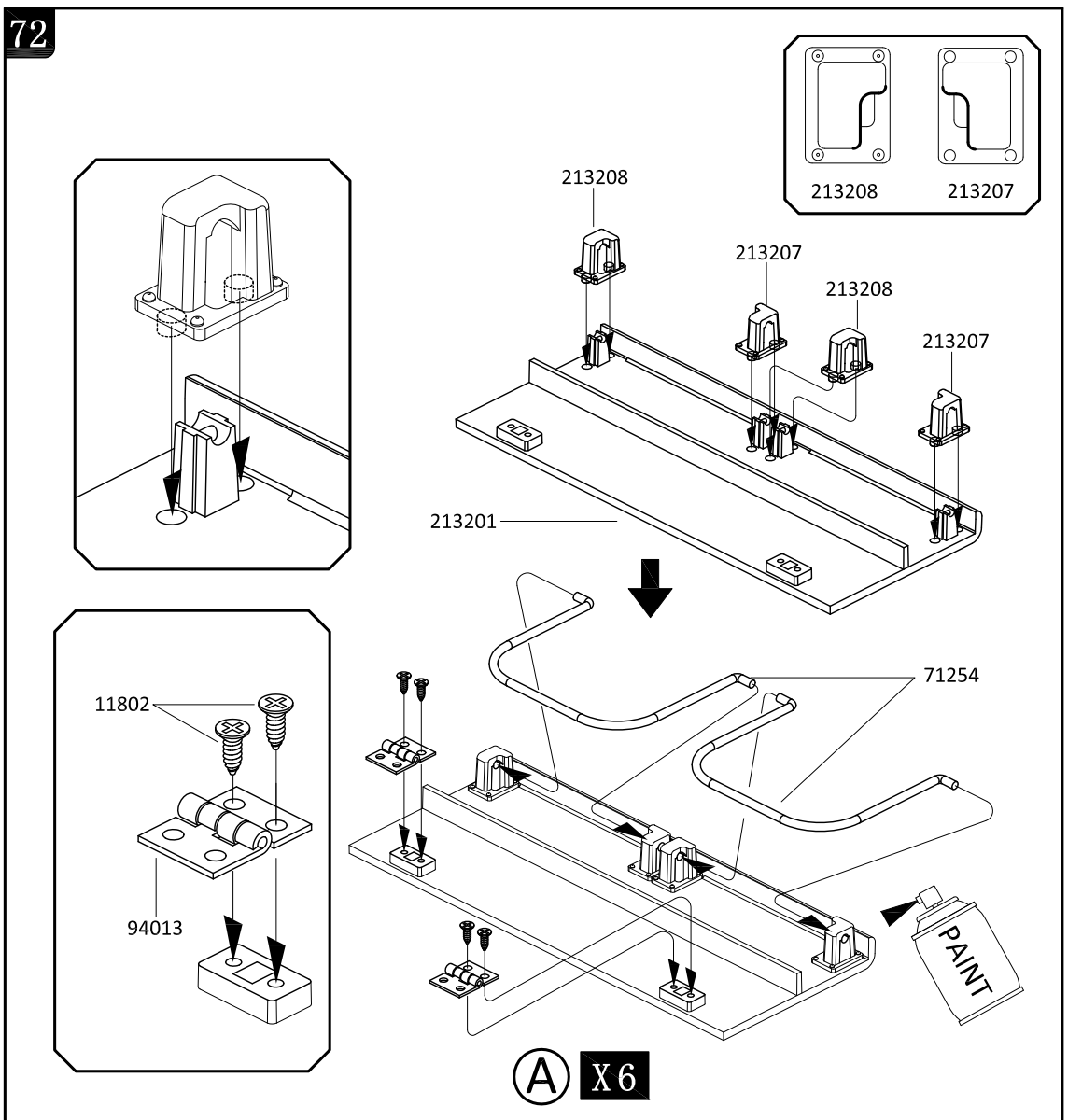
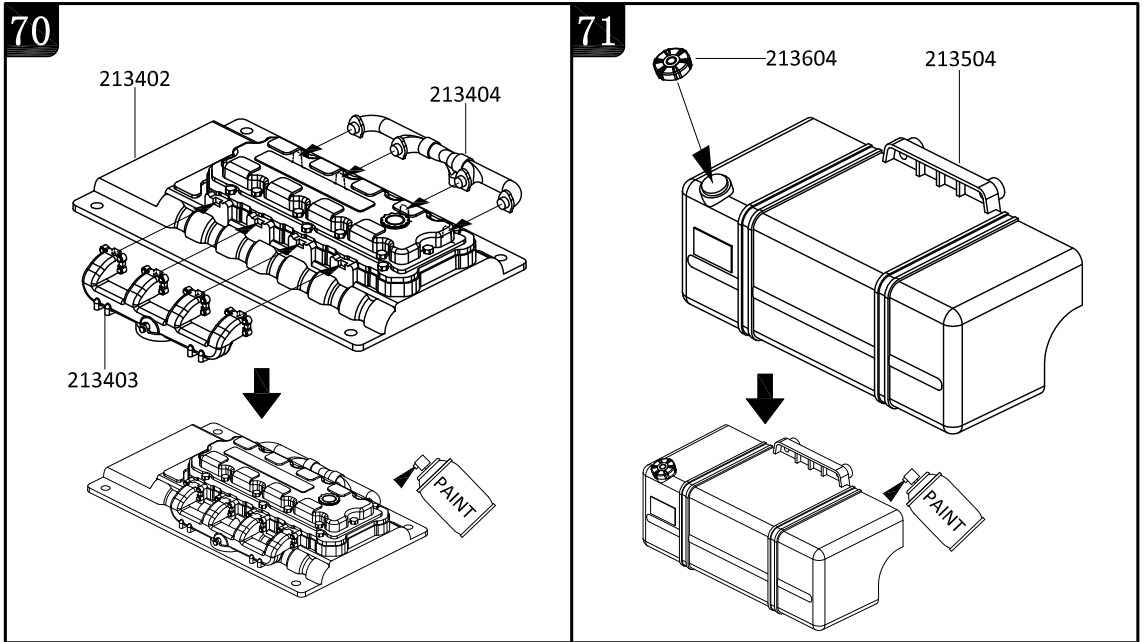

73

11802  ST1.4x4 X8

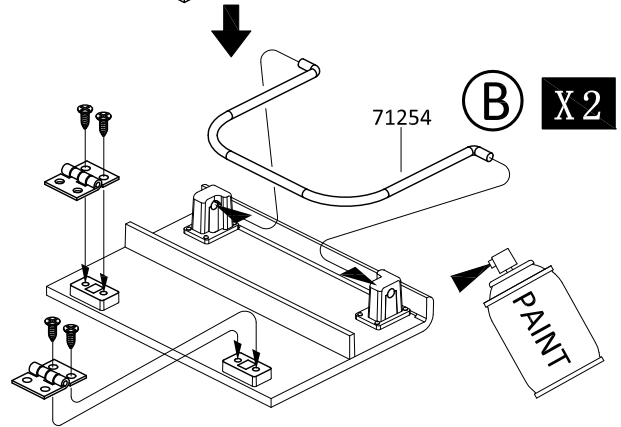
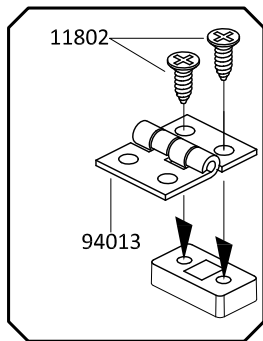
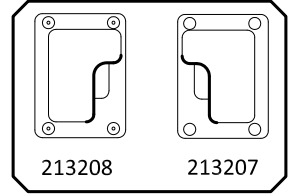
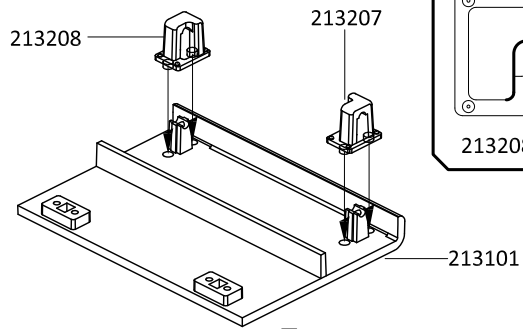
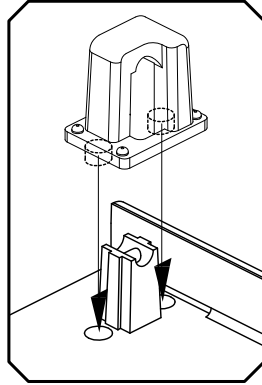

74

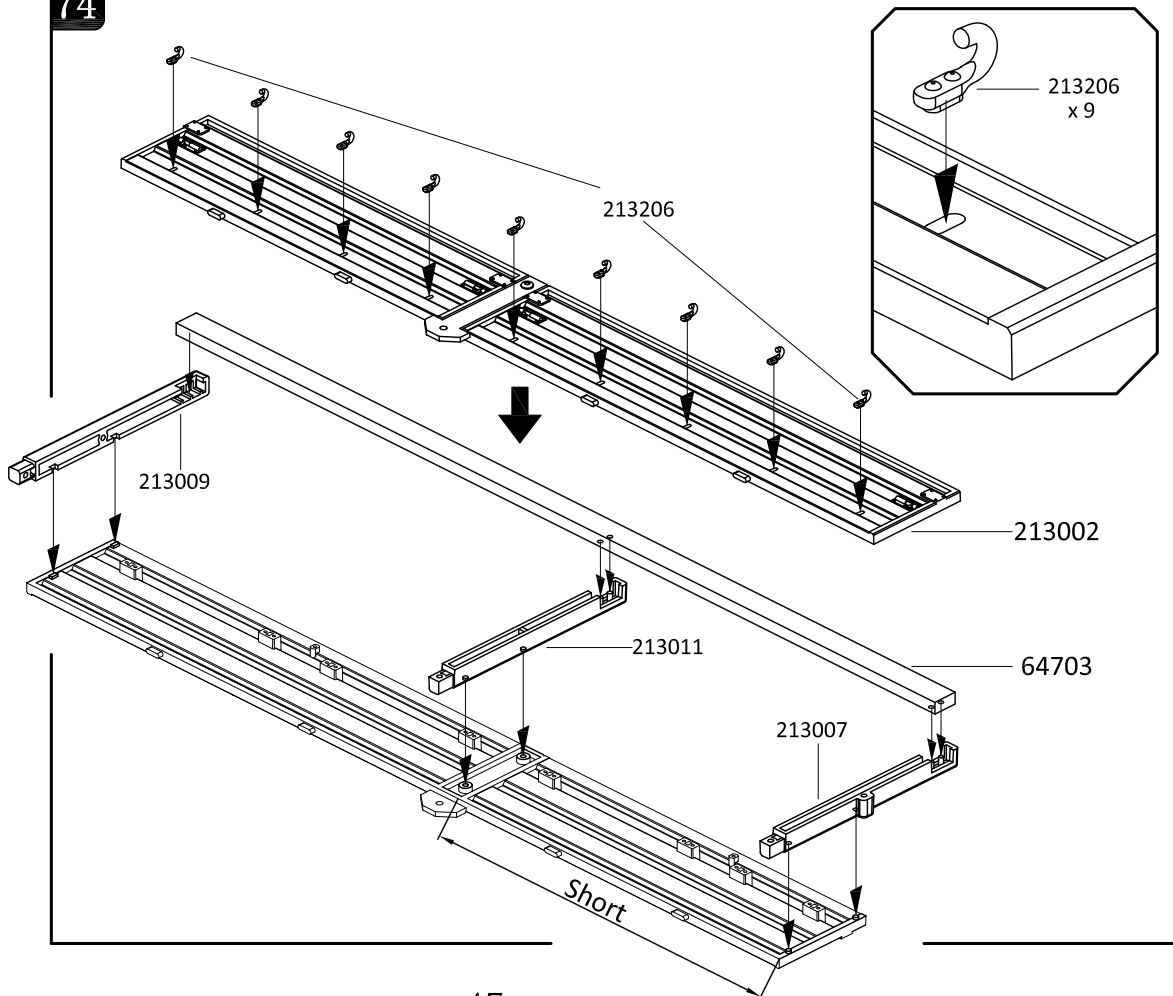

75

11802  ST1.4x4 X18

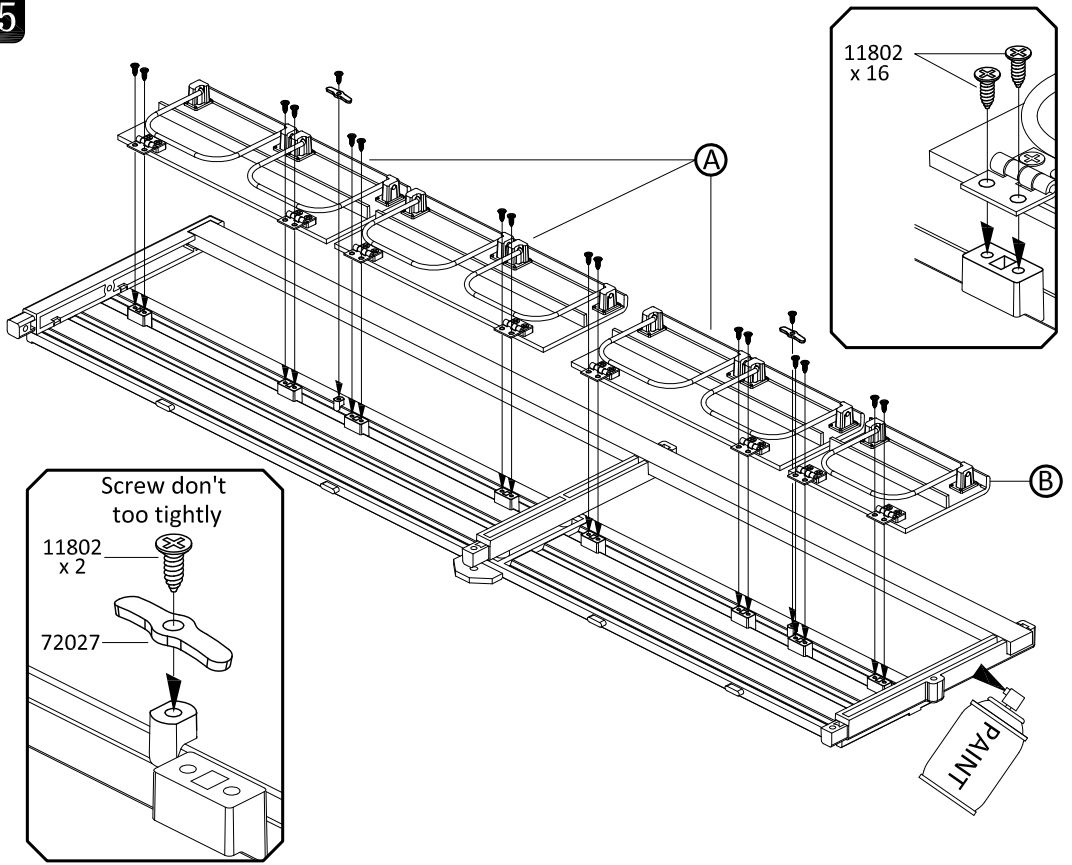

76

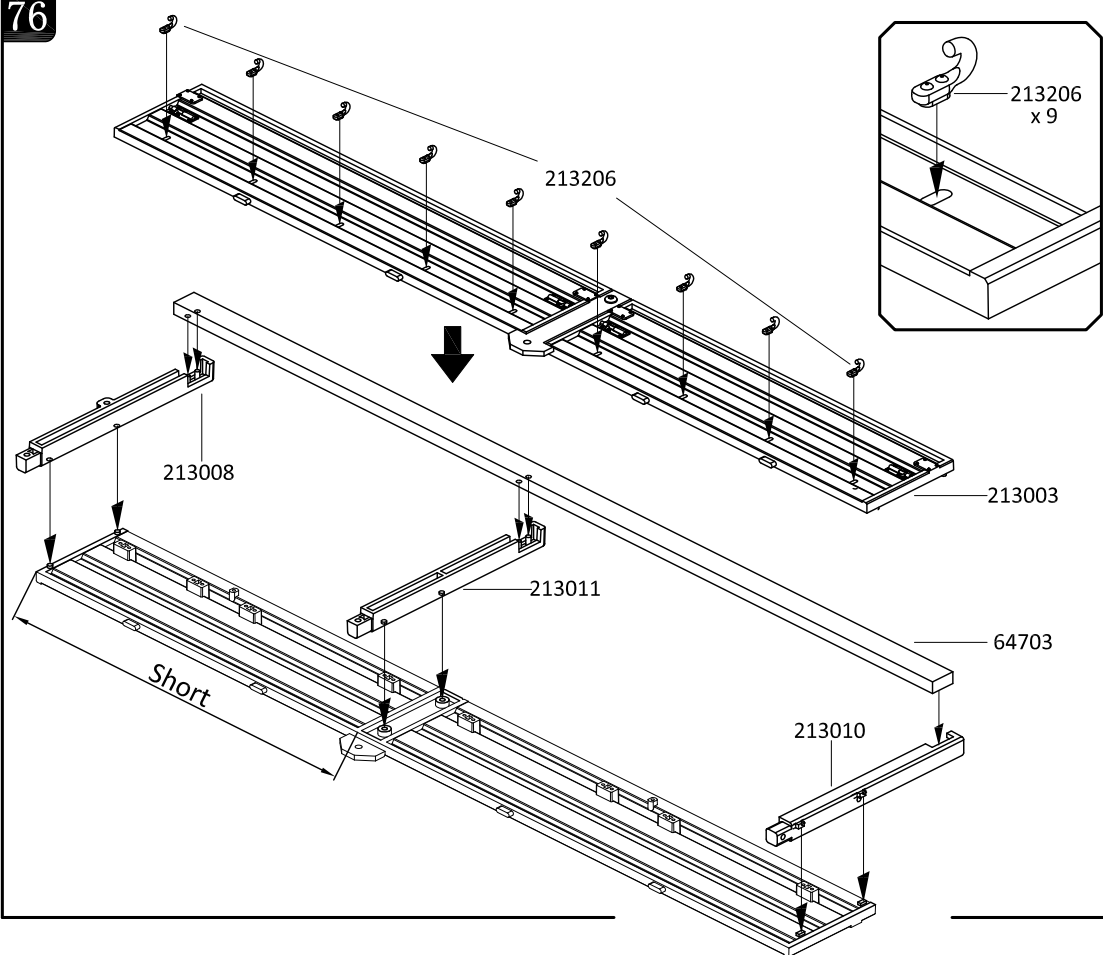

77

11802   
ST1.4x4 X18

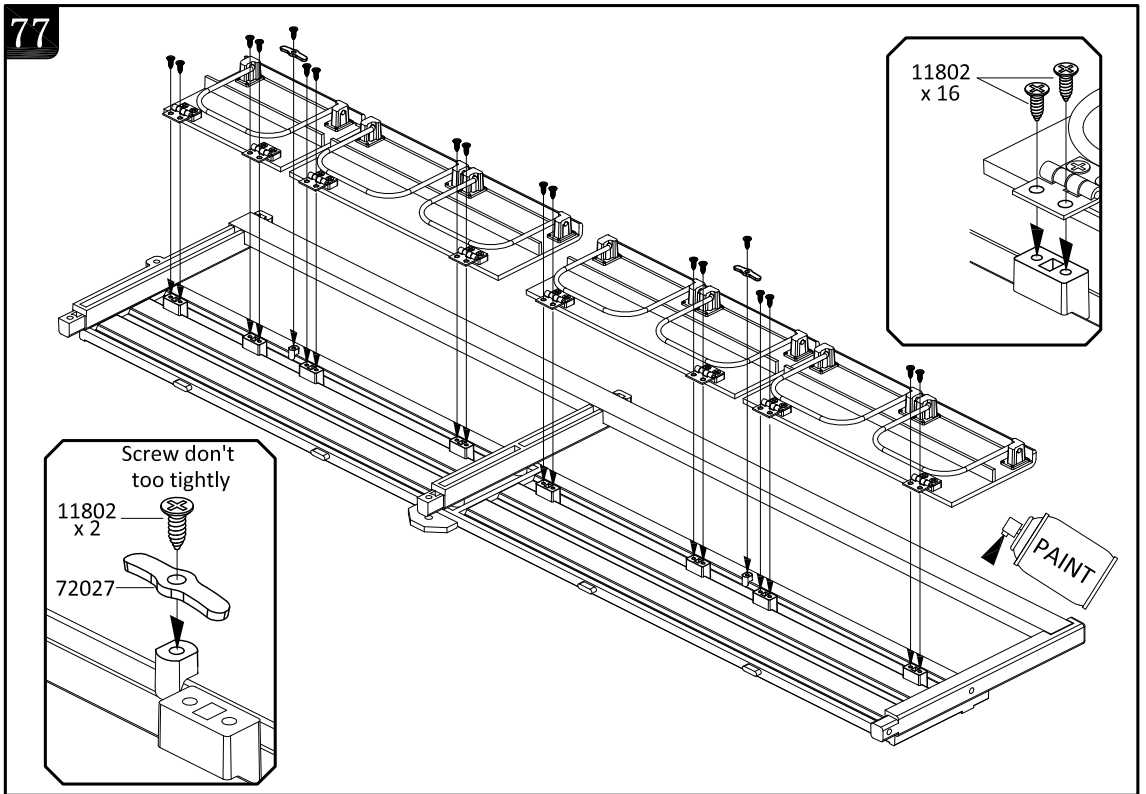
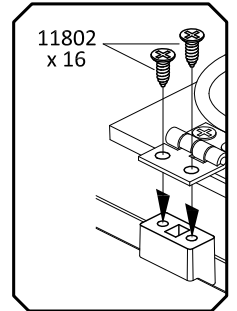
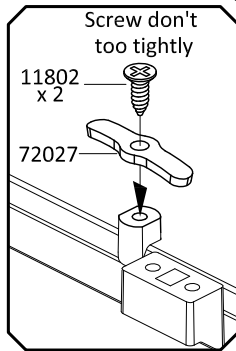

78

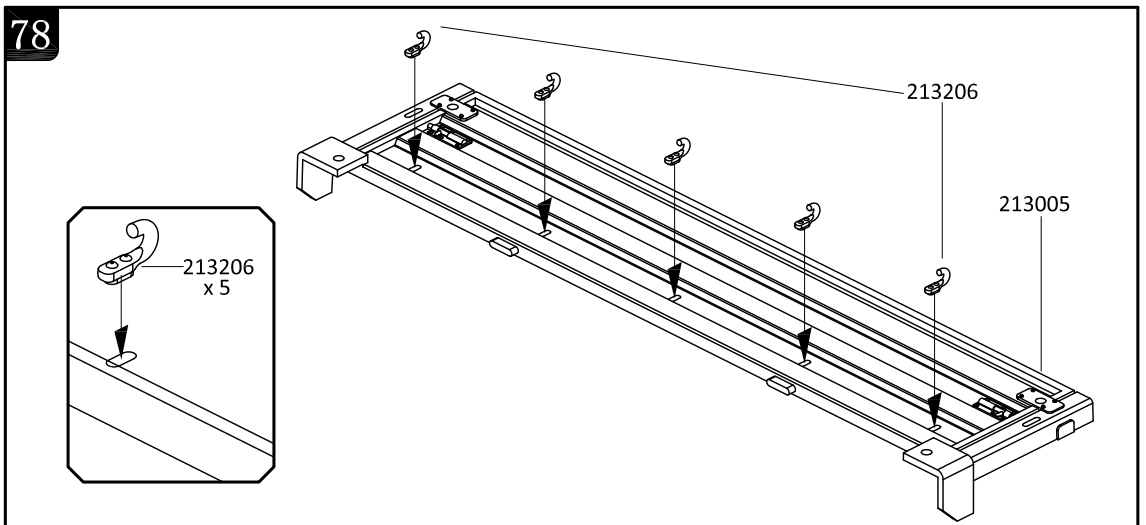
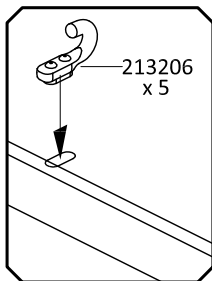

79

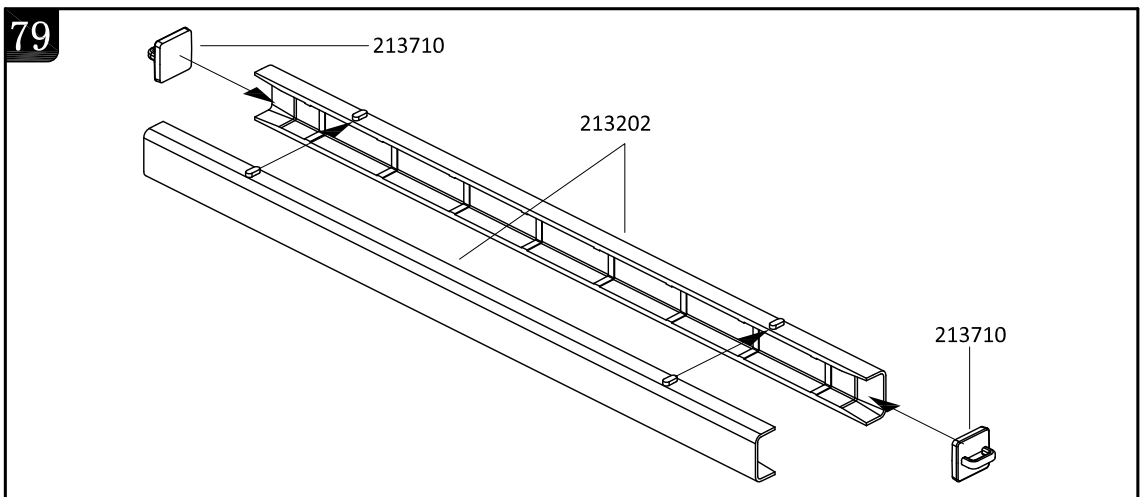

80

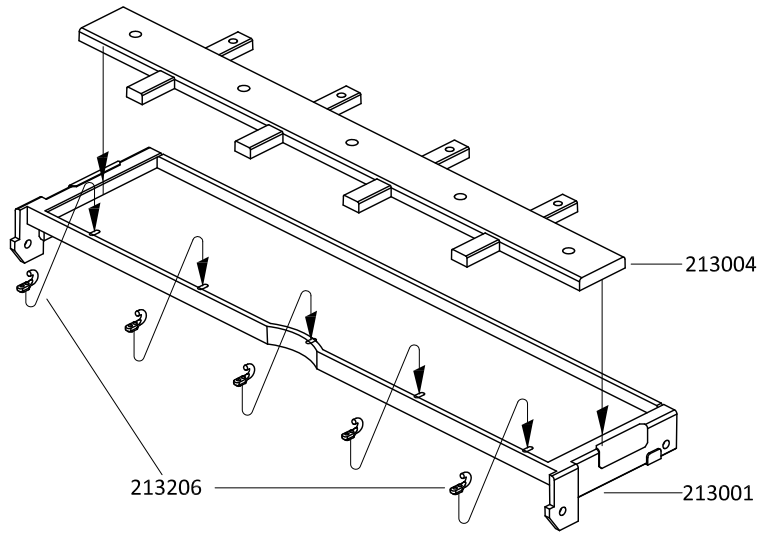
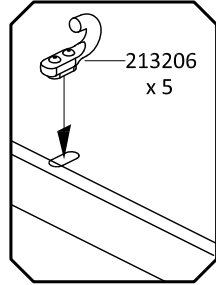

81

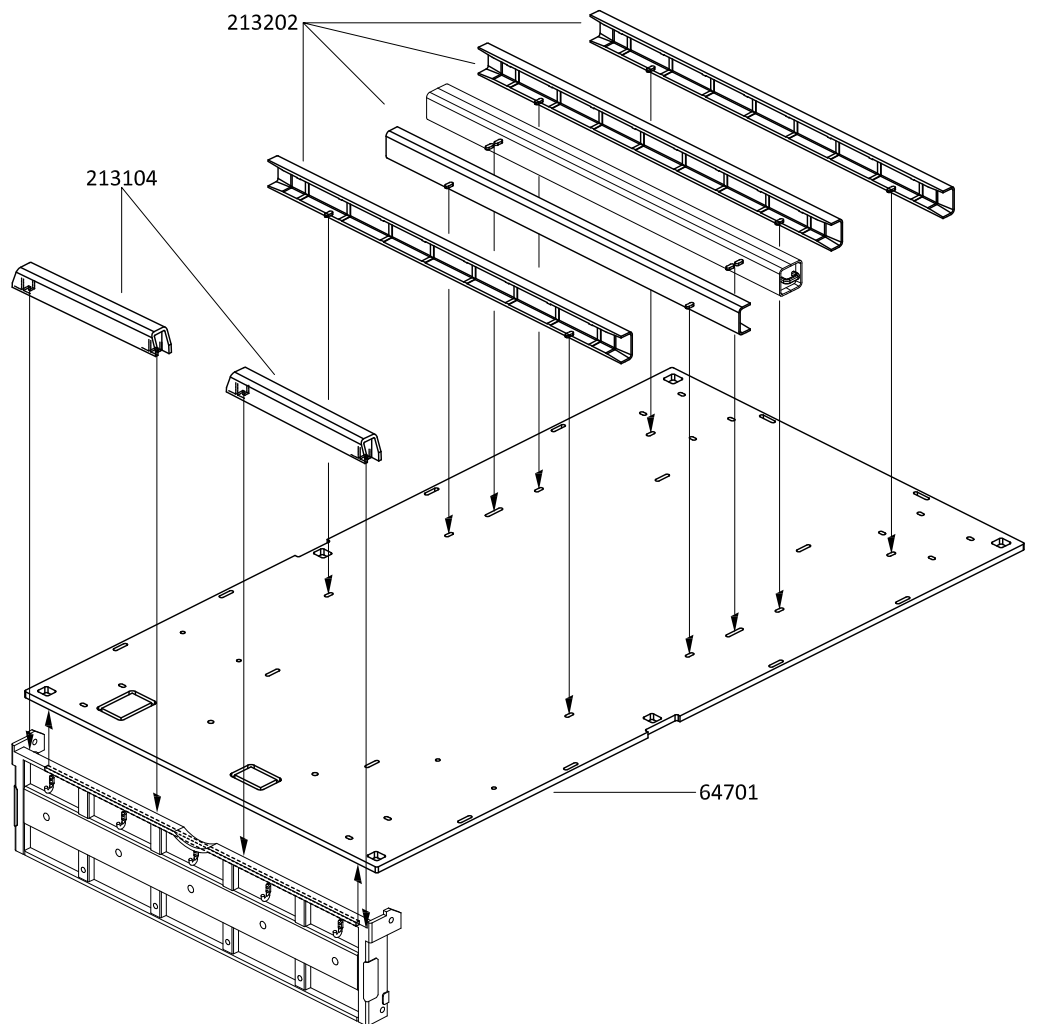

82

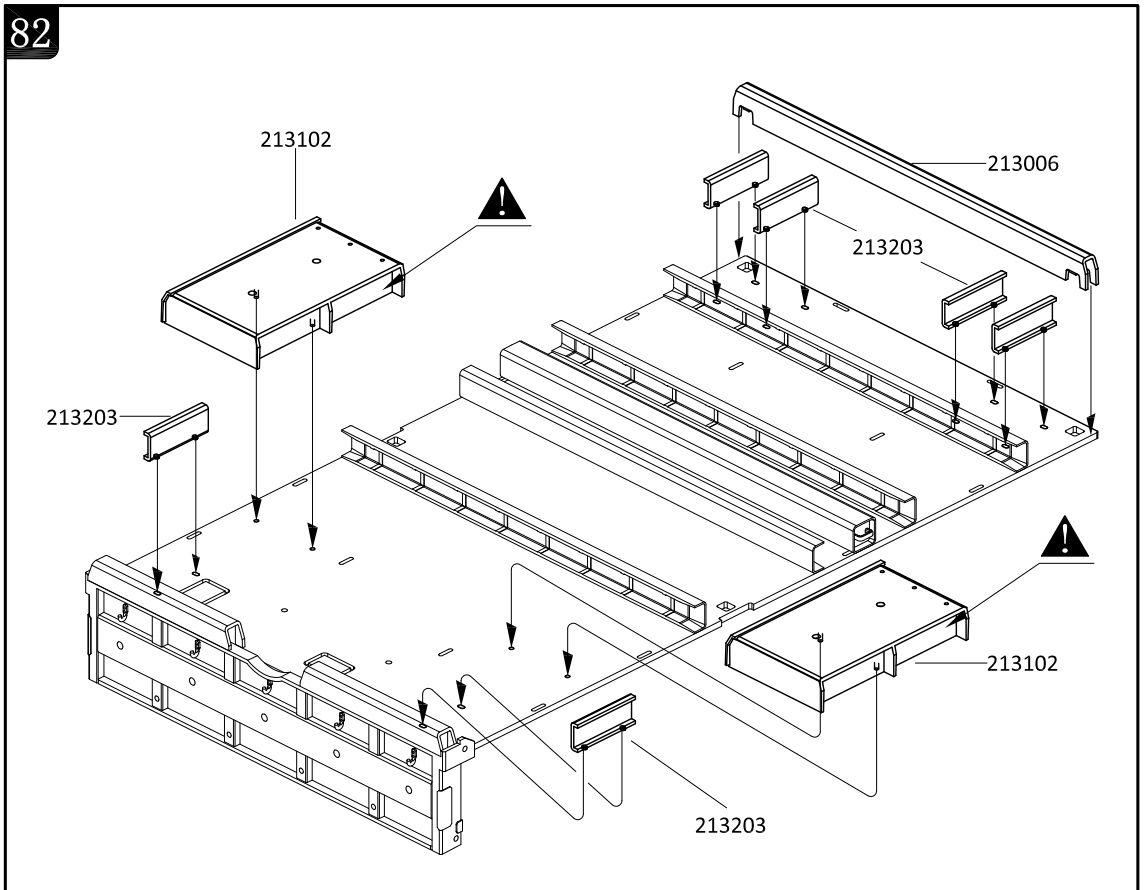

83

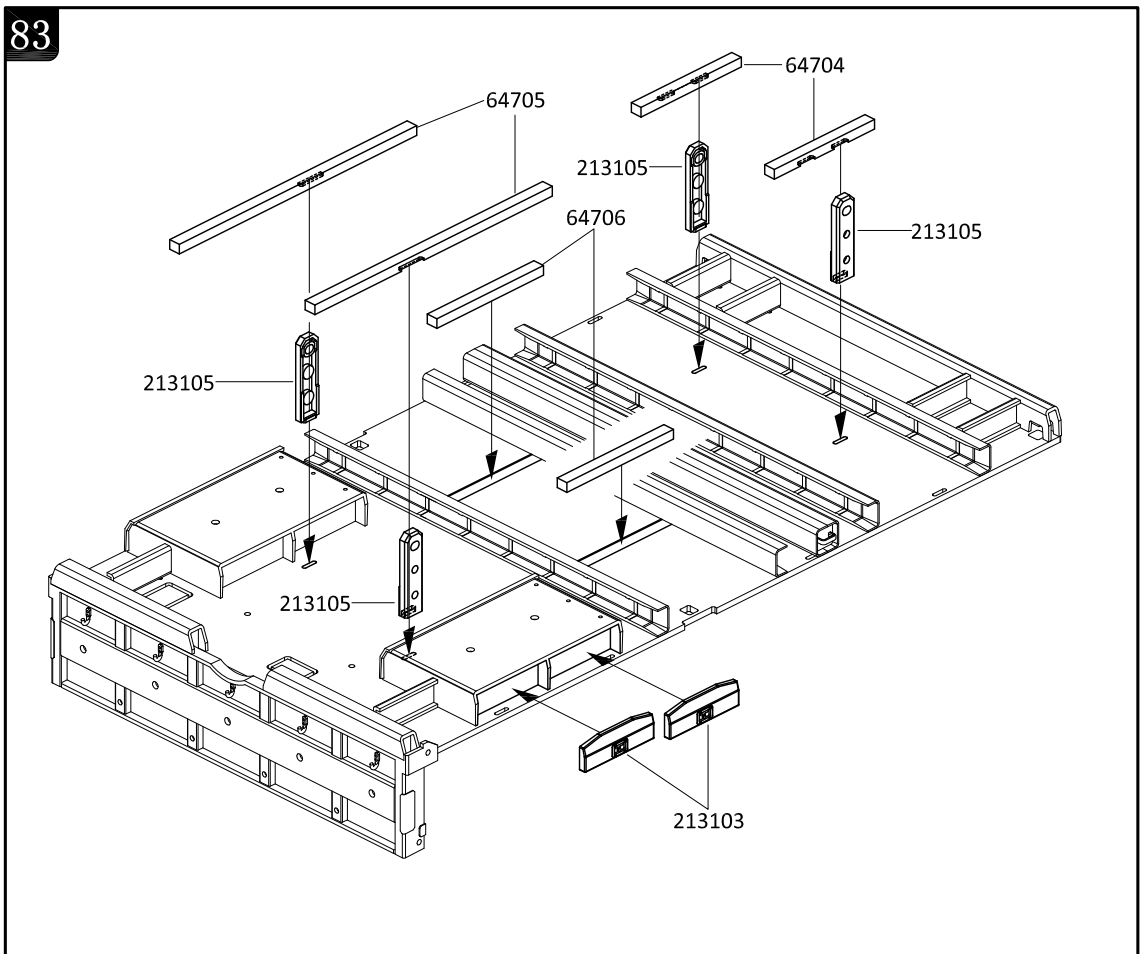

84

11202   
M2x6 X4

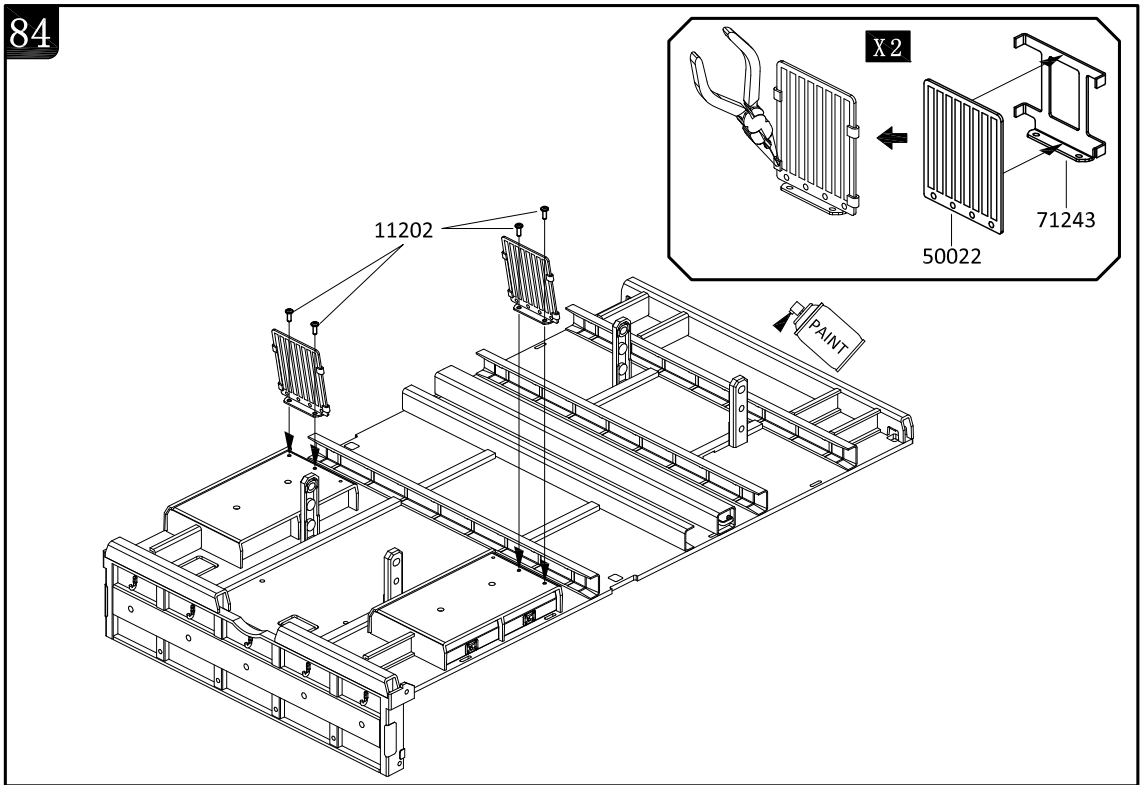

85

11207   
M3x10 X2

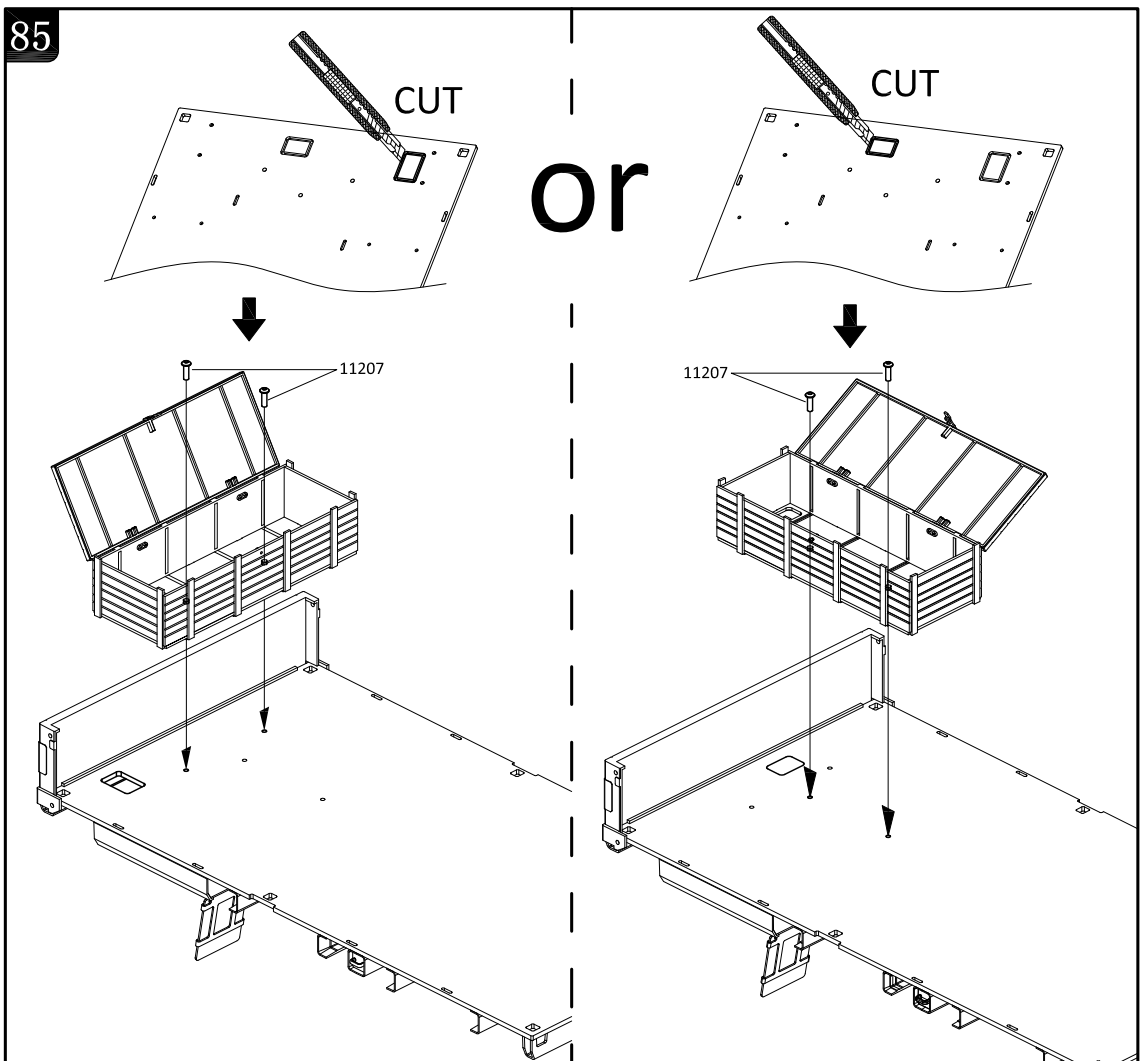

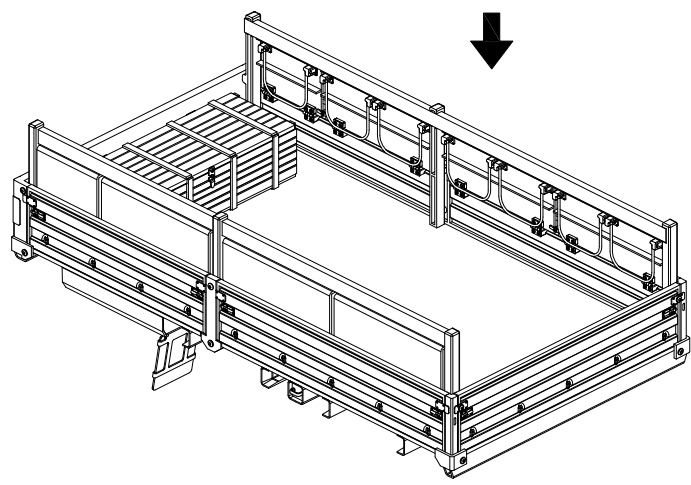
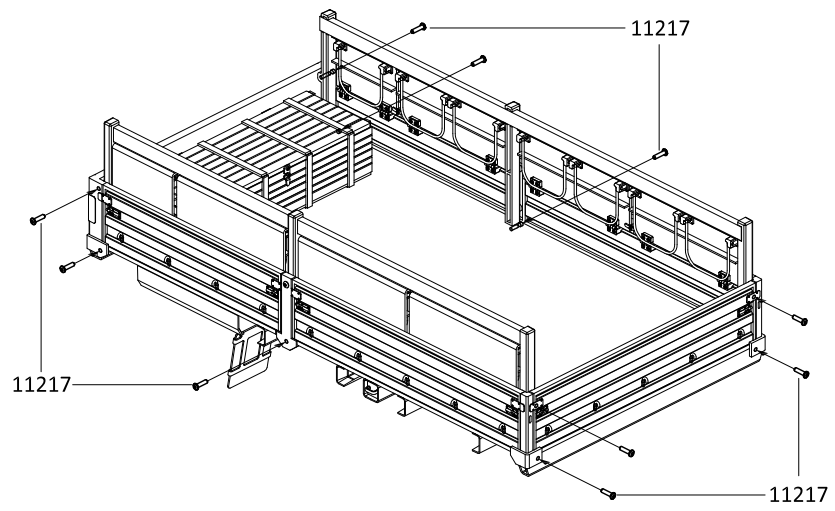
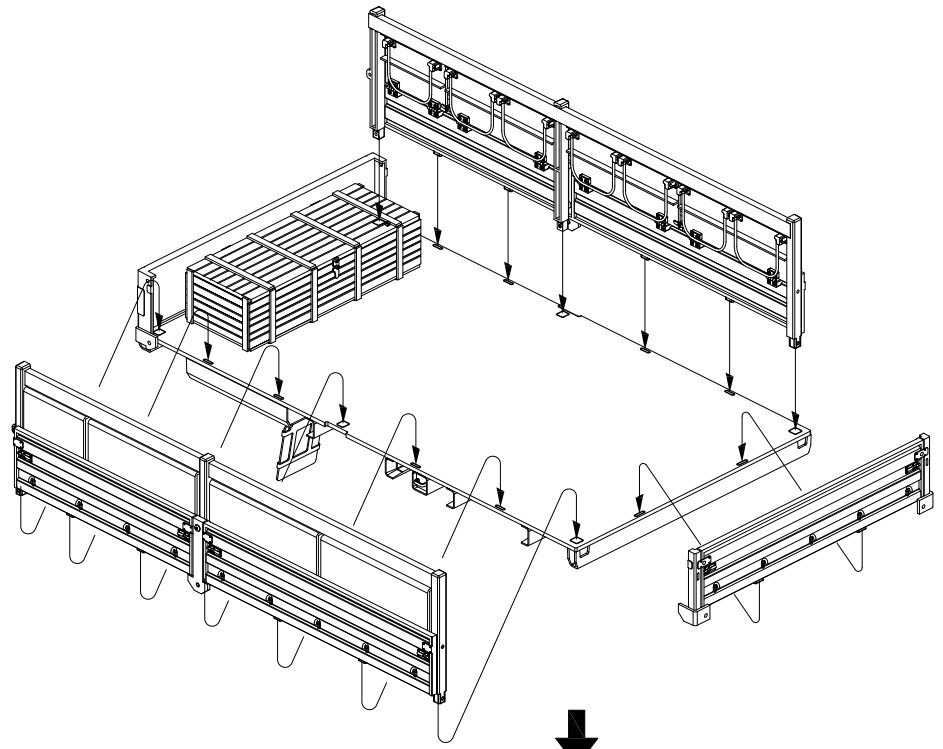

86

11217   
M2.5x10 X10



87

11216   
M2.5x6 X8

11217   
M2.5x10 X6

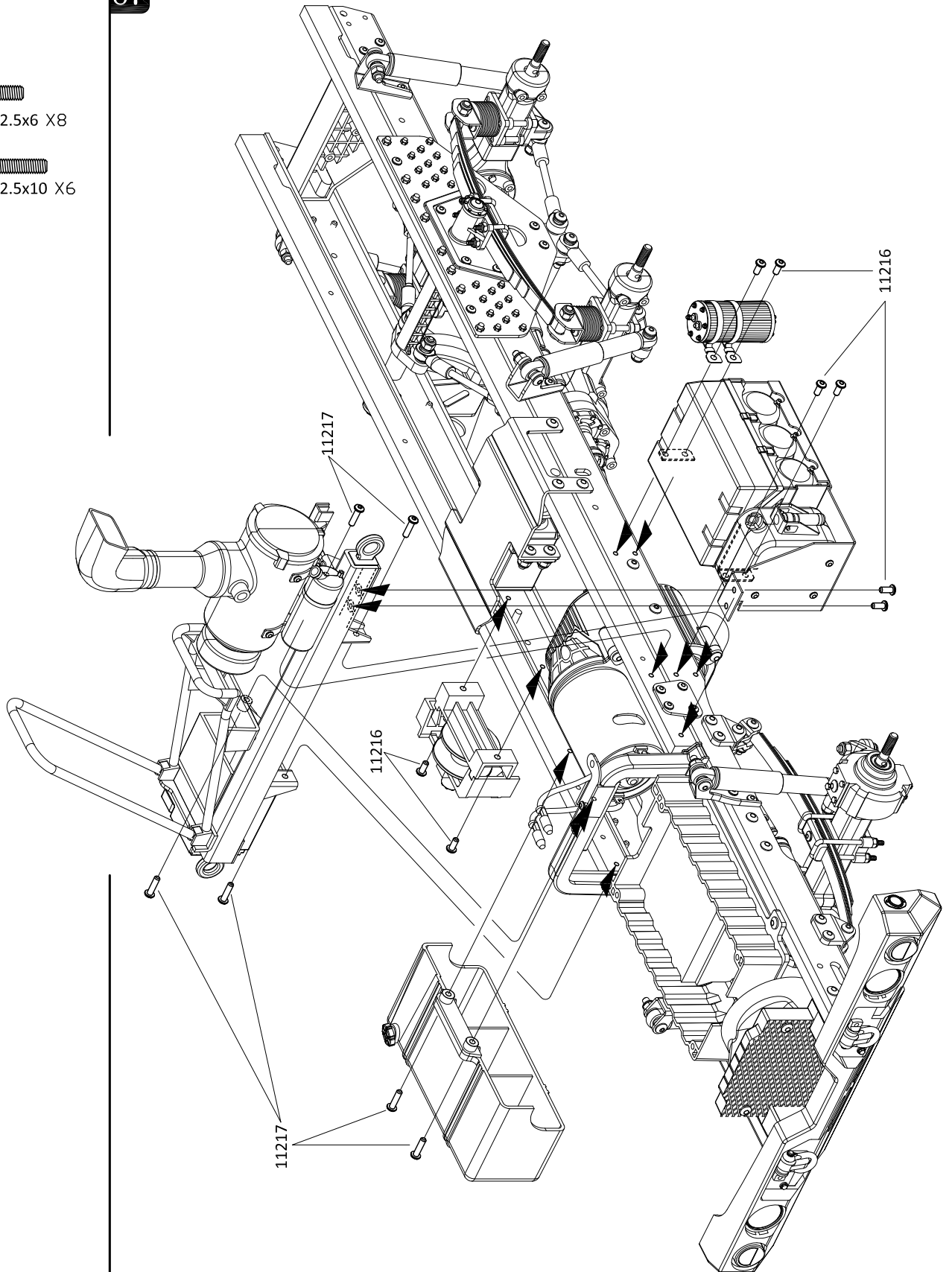

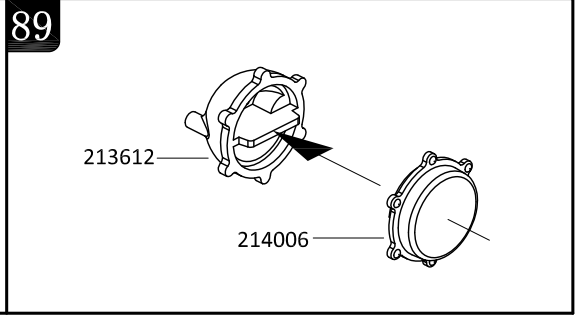
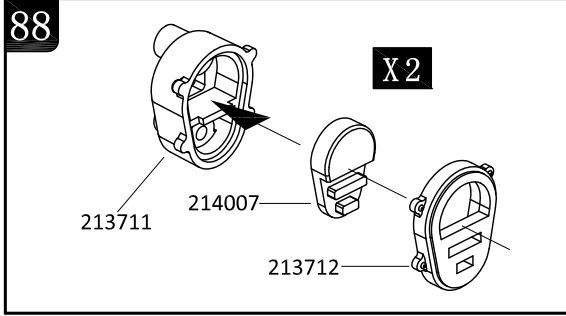

12206 M2 X8

11202 M2x6 X13

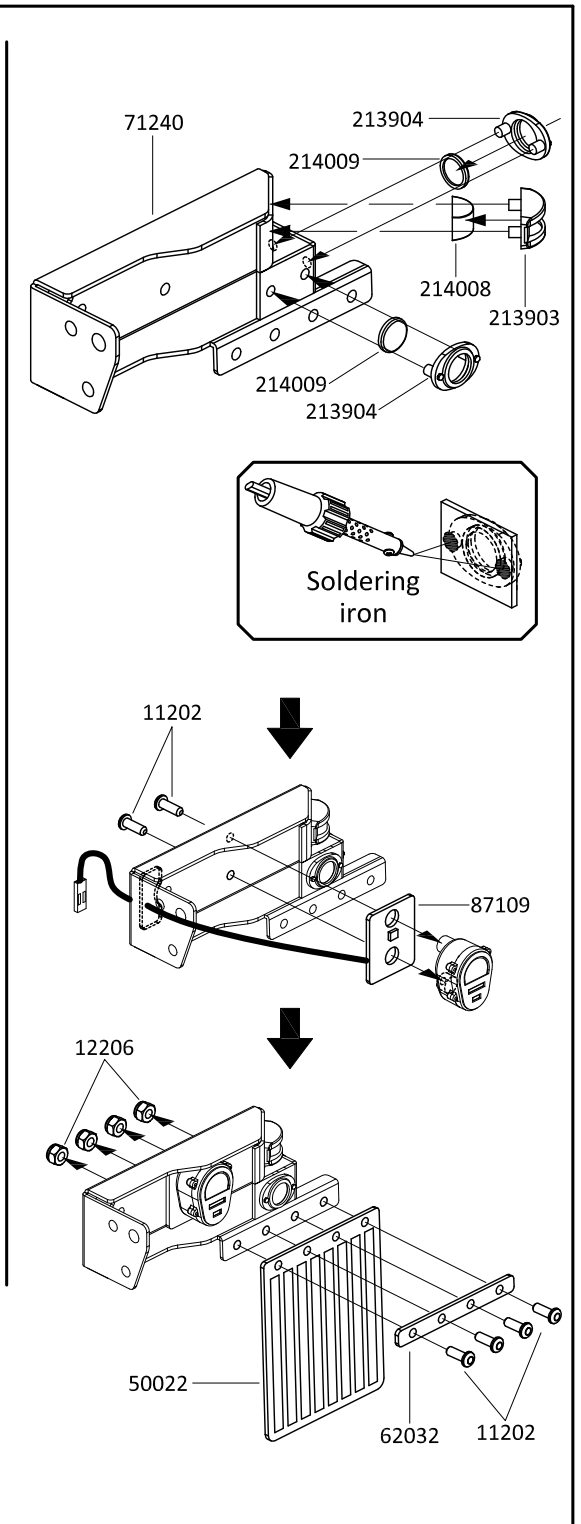
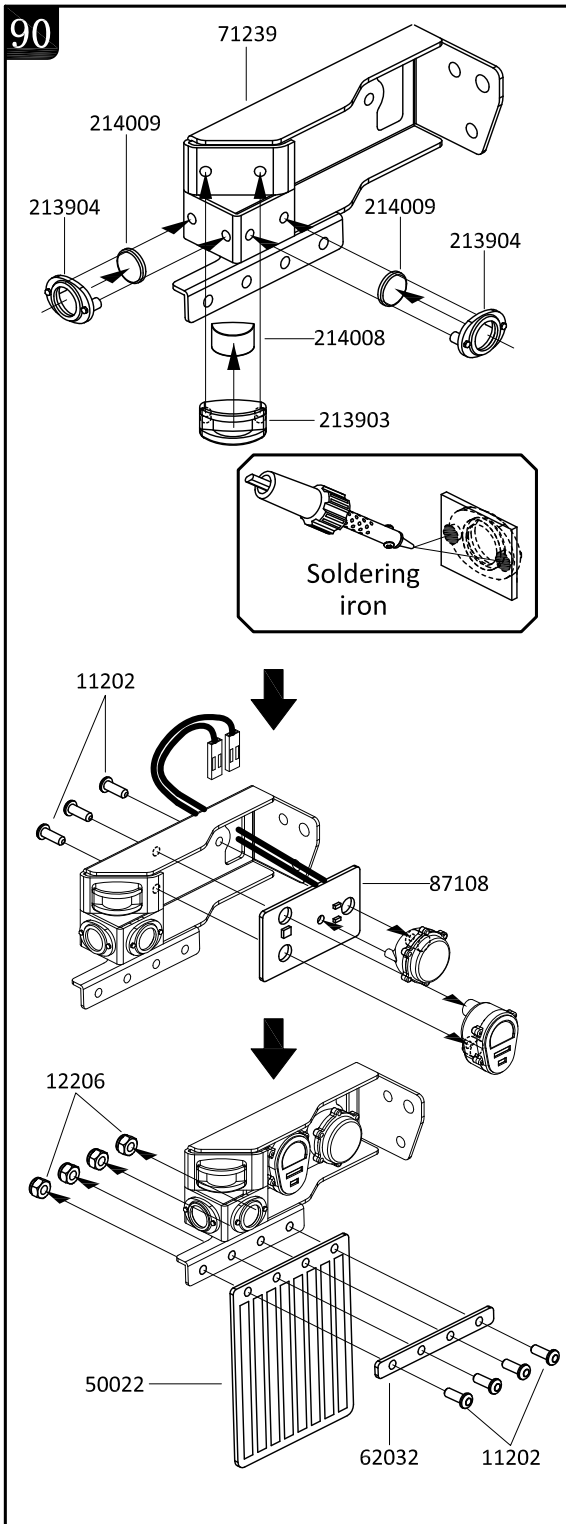
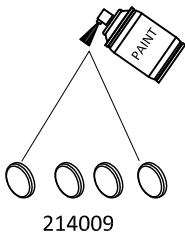
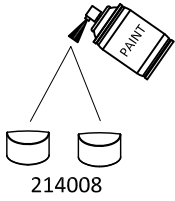

91

11216  
M2.5x6 X4

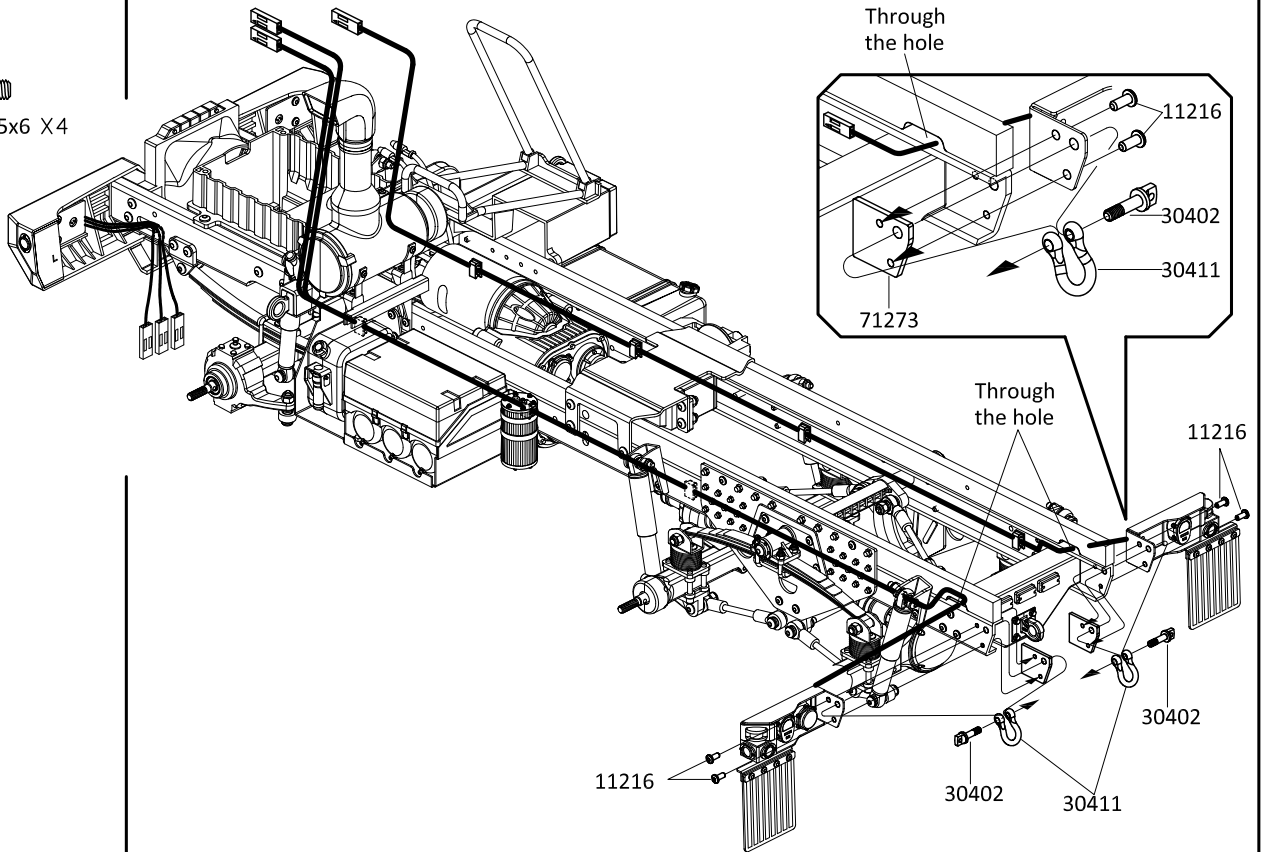

12204  
M4 X6

92

11412  
M3x3 X6

17003  
φ10xφ7x1.5 X6

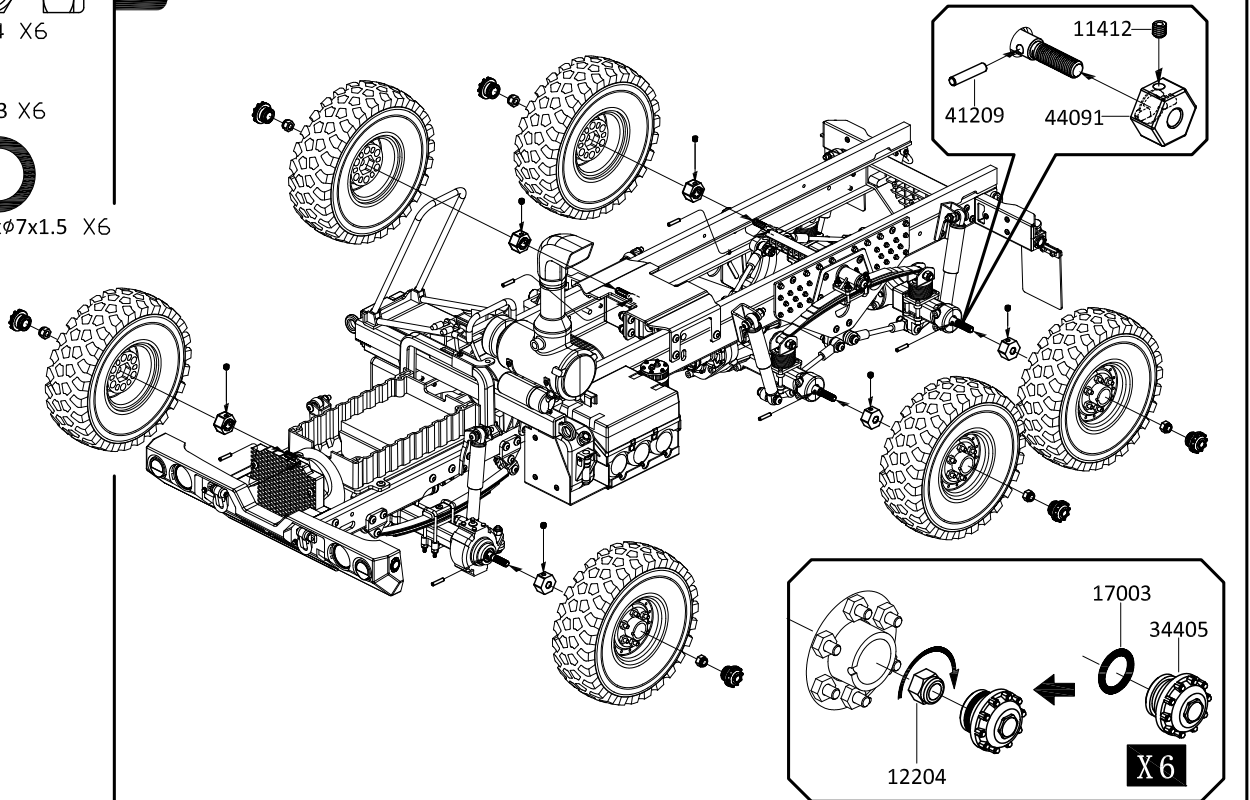

93

11207   
M3x10 X4

14102   
Ø3xØ7x0.5 X4

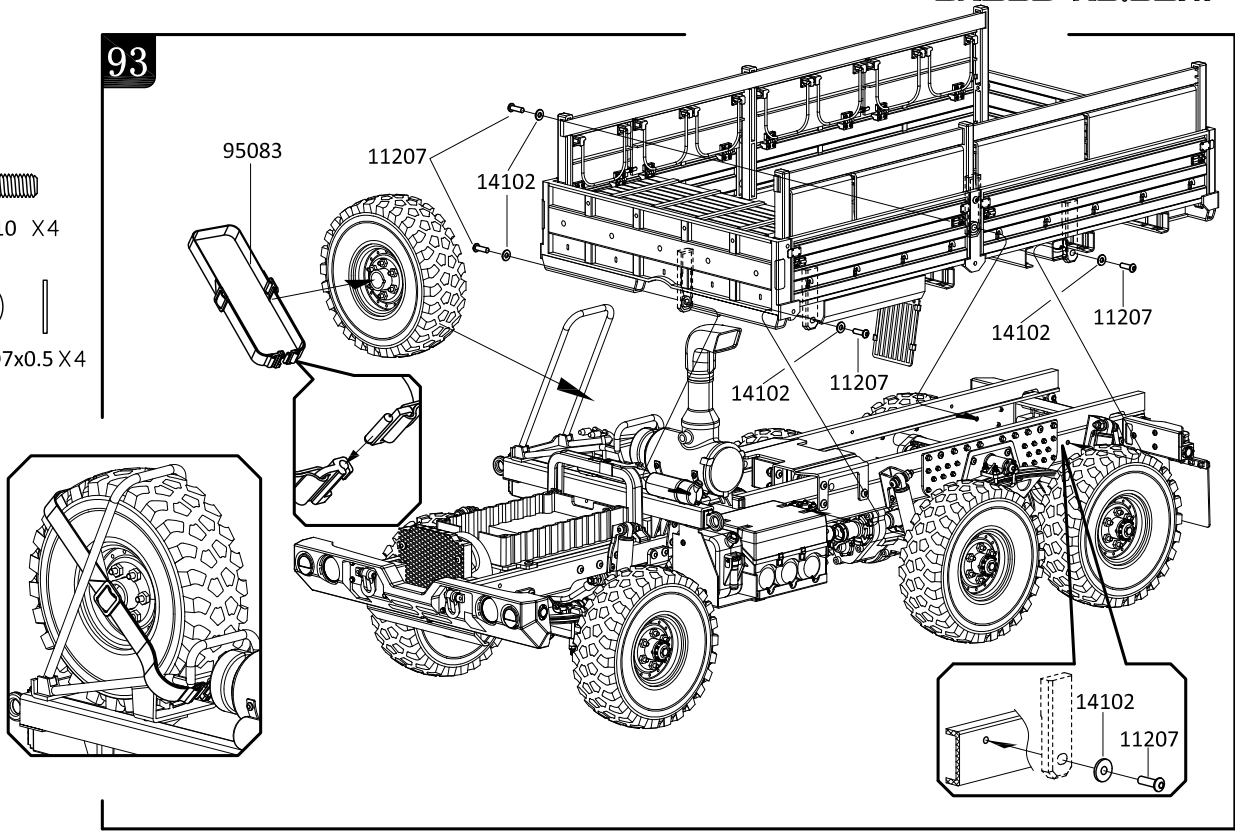

94

11207   
M3x10 X4

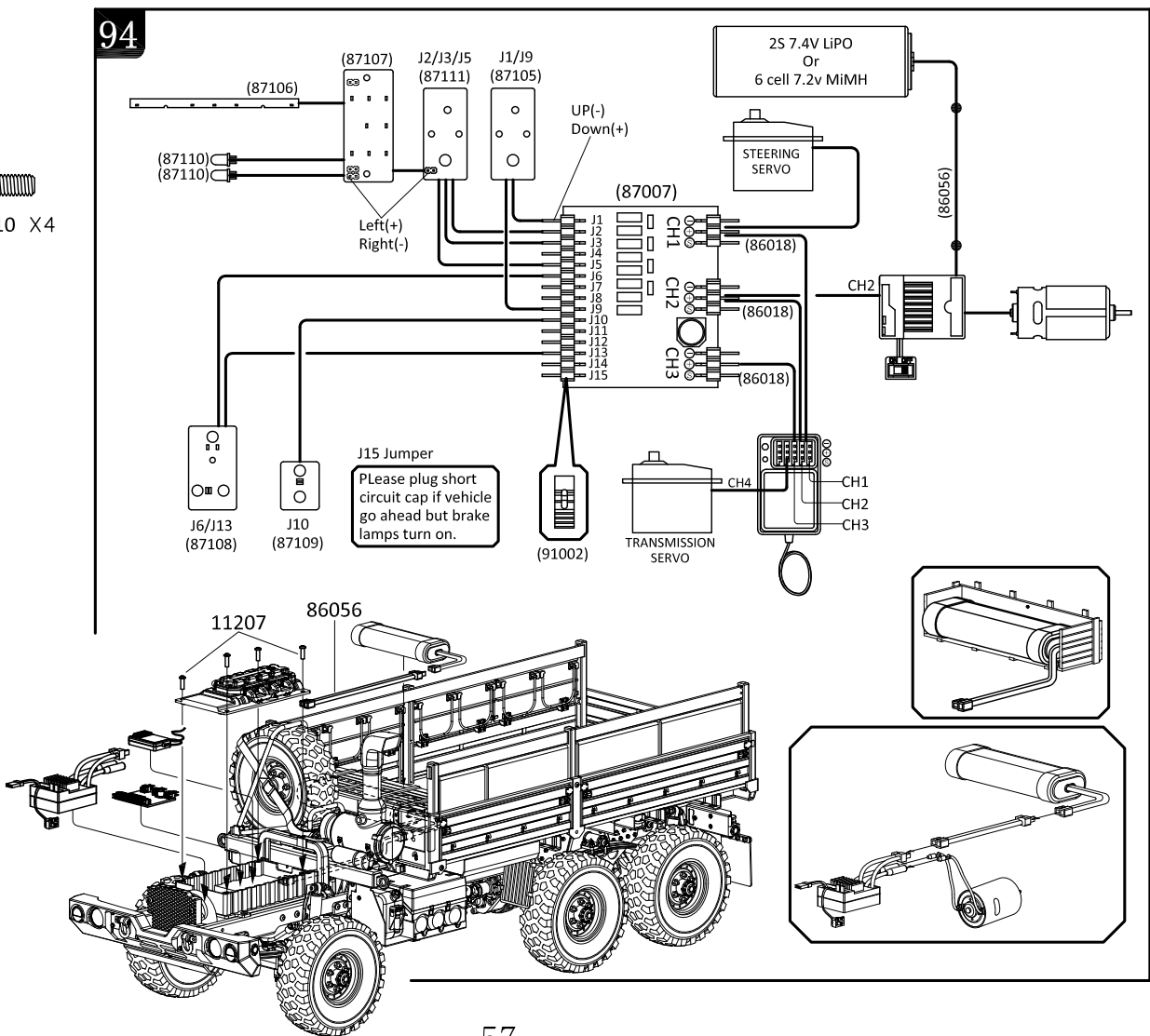

95

11207   
M3x10 X4

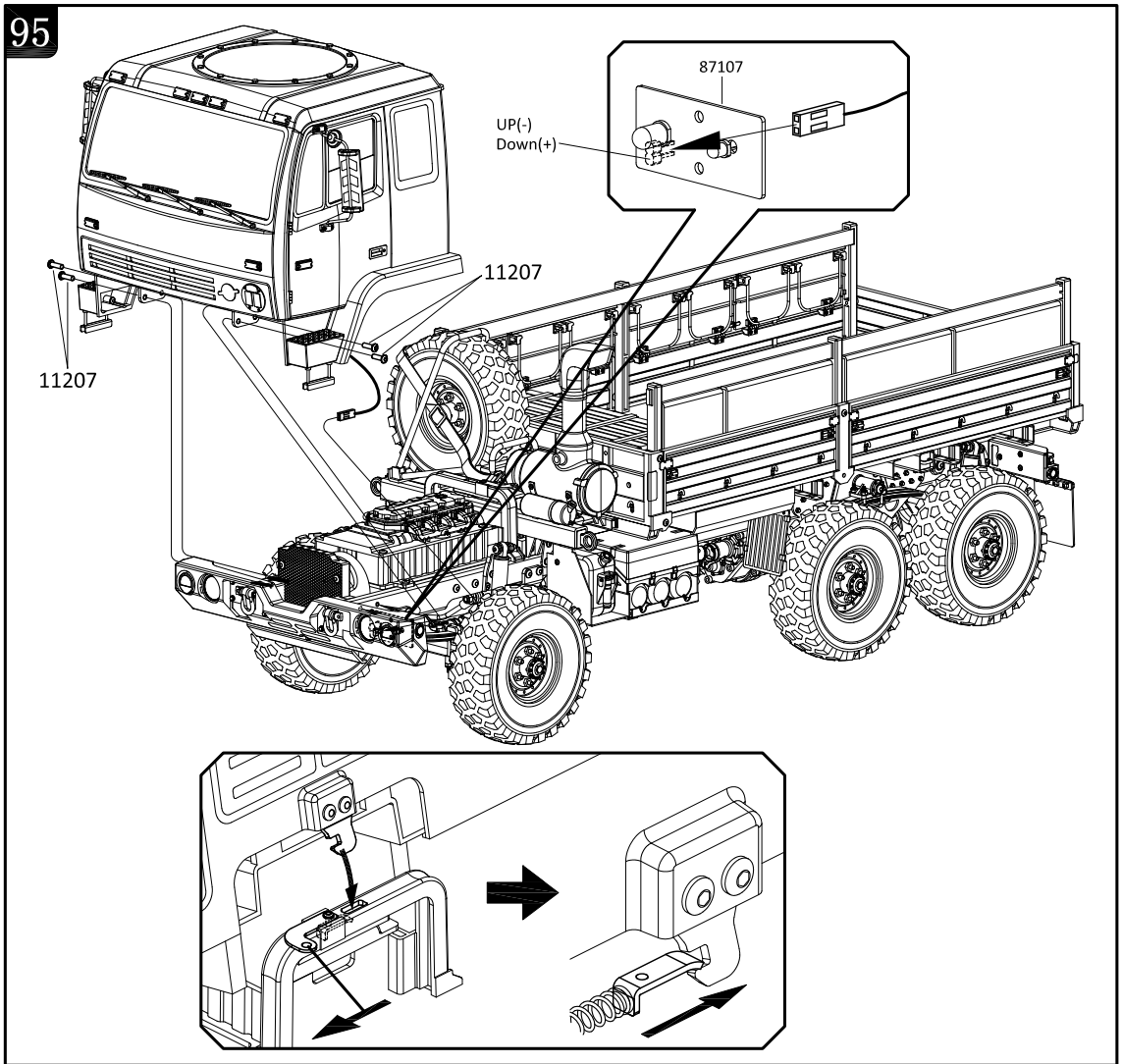

96

